



# Control Technology Inc.

5734 Middlebrook Pike  
Knoxville, Tennessee 37921  
[www.controltechnology.com](http://www.controltechnology.com)  
Toll Free: 800-537-8398

## 2500 Series <sup>TM</sup> Compact I/O System

**2500C-8-AO**

**8-CHANNEL ANALOG OUTPUT MODULE**

**2500 SERIES® COMPACT I/O**

**INSTALLATION AND OPERATION GUIDE**

**Version 2.4**

**Copyright© 2024 Control Technology Inc.  
All rights reserved.**

This manual is published by Control Technology Inc. (CTI) 5734 Middlebrook Pike, Knoxville, TN 37921. This manual contains references to brand and product names which are tradenames, trademarks, and/or registered trademarks of Control Technology Inc. Siemens®, SIMATIC®, and Series 505®, and 505® are registered trademarks of Siemens AG. Other references to brand and product names are tradenames, trademarks, and/or registered trademarks of their respective holders.

**DOCUMENT DISCLAIMER STATEMENT**

Every effort has been made to ensure the accuracy of this document; however, errors do occasionally occur. CTI provides this document on an “as is” basis and assumes no responsibility for direct or consequential damages resulting from the use of this document. This document is provided without express or implied warranty of any kind, including but not limited to the warranties of merchantability or fitness for a particular purpose. This document and the products it references are subject to change without notice. If you have a comment or discover an error, please call us toll-free at 1-800-537-8398 or email us at [sales@controltechnology.com](mailto:sales@controltechnology.com).

<b>REVISION HISTORY</b>		
V 1.0	1 Nov 2013	Initial Release
V1.1	20 Nov 2013	Corrected Section 1.9 Error Code Reporting
V1.2	26 March 2014	Corrected Module Pictures
V 1.3	17 April 2014	Corrected Section 1.4 reference to Classic Output Range
V1.4	18 January 2016	Corrected Accuracy Rating from .1% to .15%.
V1.5	10 May 2016	Corrected Error Codes in Section 1.9, added range info 1.7 and HEX equivalent values in Binary Example Table in 1.8. Added a new section and Figure 5 to describe location of CN6 and selecting voltage range operation in Classic Mode. pdb
V1.6	9/25/2017	Added Display Error Codes in Section 3.1
V1.7	19 March 2018	Changes made in Section 1.7 The following sentences were corrected: "The maximum valid output value that can be written is +32767 or the lowest value written can be -32767. Values above +32767 or below -32767 indicate error conditions. +/-32768 will be flagged by Workshop as an INVALID VALUE."  The corrected sentence reads as follows: "The maximum valid output value that can be written is +32767 or the lowest value written can be -32767. +32768 will be flagged by Workshop as an INVALID VALUE."
V1.8	19 June 2018	Added Power Cycle Reaction Tables in Section 2.8 Figures 7 through 11.
V1.9	17 July 2018	Added Profibus to Figures 8 through 11.
V2.0	9/13/18	Corrected reference to Digital Filtering on Page 7. Digital Filtering did not apply to the Analog Output.
V2.1	1/25/2022	Added Caution Statement for User Replaceable Fuse.
V2.2	8/22/2022	Added fuse info for F3 User Power Supplied 24VDC Fuse in Section 1.9.1 and fuse location in Figure 3. pdb.
V2.3	12/6/2023	ADDED REFERENCE IN SECTION 1.11 TO SECTION 2.8. PDB
V2.4	7/3/2024	Added additional information on Hot-Swapping in Section 2.5

---

## **PREFACE**

---

This **Installation and Operation Guide** provides reference information for the CTI 2500 2500C-8-AO 8-Channel Analog Output Model for 2500 Series® Compact I/O. We assume you are familiar with the operation of CTI 2500 Series® programmable controllers. Refer to the appropriate user documentation for specific information on the 2500 Series® programmable controllers and I/O modules.

This Installation and Operation Guide is organized as follows:

- Chapter 1 provides a description of the module.
- Chapter 2 covers installation, setup, and wiring.
- Chapter 3 covers trouble shooting.
- Appendix 1 covers the modules specifications.

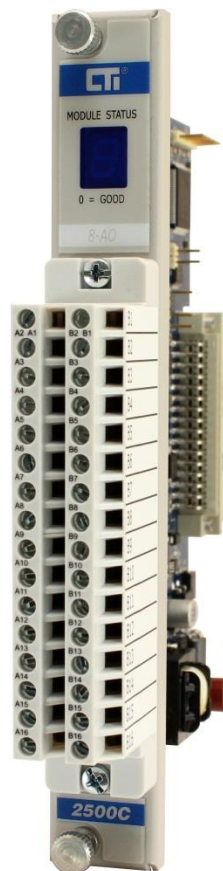

---

## **USAGE CONVENTIONS**

---

### **NOTE**

*Notes alert the user to special features or procedures.*

### **CAUTION**

*Cautions alert the user to procedures that could damage equipment.*

### **WARNING**

**Warnings alert the user to procedures that could damage equipment and endanger the user.**

---

## **TABLE OF CONTENTS**

---

<b>CHAPTER 1 OVERVIEW .....</b>	<b>5</b>
1.1 Introduction.....	5
1.2 Front Panel Description .....	5
1.3 Asynchronous Operation.....	6
1.4 Modes of Operation .....	6
1.5 Output Resolution .....	7
1.6 Accuracy.....	7
1.7 Digital to Analog Conversion.....	7
1.8 Module Setup from the PLC in Classic Plus Mode.....	8
1.9 Error conditions reported:.....	9
1.10 Using the Module with a Built-In 20% Offset Calculation .....	10
1.11 Zero or Last Value Default .....	10
<b>CHAPTER 2 INSTALLATION &amp; SETUP .....</b>	<b>11</b>
2.1 Installation Planning.....	11
2.2 Unpacking the Module.....	15
2.3 Configuring the Module .....	15
2.4 Selecting $\pm 5$ VDC Range for Classic Mode Operation.....	17
2.5 Physical Installation .....	18
2.6 Connecting Field Wiring .....	19
2.7 Initial Power On Indications.....	20
2.8 Output Channel's Reaction to Power Cycling and Communication Loss ..	20
<b>CHAPTER 3 TROUBLE SHOOTING .....</b>	<b>23</b>
3.1 Status Display .....	23
3.2 WX Error Codes.....	23
3.3 24VDC User Supplied Power Source Error .....	24
<b>APPENDIX 1 2500C-8-AO PRODUCT SPECIFICATIONS .....</b>	<b>25</b>
<b>CTI WARRANTY.....</b>	<b>27</b>
<b>REPAIR POLICY.....</b>	<b>29</b>

---

## **TABLE OF FIGURES**

---

Figure 1 2500C-8-AO Front Panel .....	5
Figure 2 Asynchronous Operation Diagram .....	6
Figure 3 2500C-8-AO JP11 and F3 location on PCB.....	16
Figure 4 CN6 Jumper Pins 1 & 4 Location.....	17
Figure 5 Physical Installation Picture .....	18
Figure 6 2500C-8-AO Wiring Connector Diagram.....	19
Figure 7 Classic Mode Output to Power Cycling in the Local Base .....	20
Figure 8 Classic Mode Output to Power Cycling with RIO or Profibus Communications .....	21
Figure 9 2500C-8-AO Classic Mode Power Cycling without RIO or Profibus Communications .....	21
Figure 10 2500C-8-AO Classic Plus Mode Output Power Cycling with RIO or Profibus Communications .....	22
Figure 11 2500C-8-AO Classic Plus Mode Output Power Cycling without RIO or Profibus Communications .....	22
Figure 12 Figure 122500C-8-AO Example of Trapping for Power Supply Error Code is an example ladder rung for trapping for the Power Supply Error Code. ....	24
Figure 13 2500C-8-AO Example of Trapping for Power Supply Error Code .....	24

---

## CHAPTER 1 OVERVIEW

---

### 1.1 Introduction

The CTI 2500C-8-AO 8-Channel Analog Output Module is a member of Control Technology's 2500C Compact I/O modules compatible with the 2500 Series® Compact programmable controllers. It is designed to translate a digital output word (WY) into an analog output signal which is then sent to a field device.

#### Features

- 8 analog outputs
- Supports Classic and Classic Plus Mode
- Output ranges 0-5V, 0-10V, 0-20mA, +/-5V, +/-10V, +/-20mA
- 7 Segment Display for Module Status indication
- No user calibration required
- Software Configurable Range Selection
- Uses 2500C-32F removable wiring connector

### 1.2 Front Panel Description

The module front panel includes a 7-segment status display for showing module status, and a 32-pin removable I/O wiring connector.

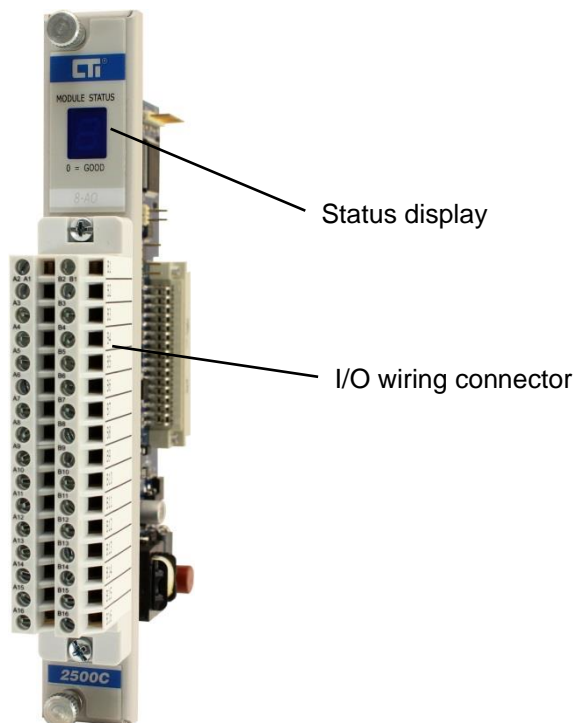

**Figure 1 2500C-8-AO Front Panel**

### 1.2.1 Status Display

The Status Display will be illuminated with a “0” when the module is functioning normally. If the Status Display is not lit or it’s displaying something other than “0”, refer to Chapter 3 for troubleshooting.

### 1.2.2 I/O Wiring Connector

The 2500C-8-AO module uses the standard 2500C-32F Field Wiring Connector. This connector provides 32 connections and accepts 14-22 AWG wires.

## 1.3 Asynchronous Operation

The module operates asynchronously with respect to the PLC (a scan of the PLC and input sampling of the module do not occur at the same time). Instead, the module will translate all analog inputs in one module update (3.5 milliseconds maximum) and store the translated words in buffer memory. The PLC retrieves the stored words from the module buffer memory at the start of the I/O scan.

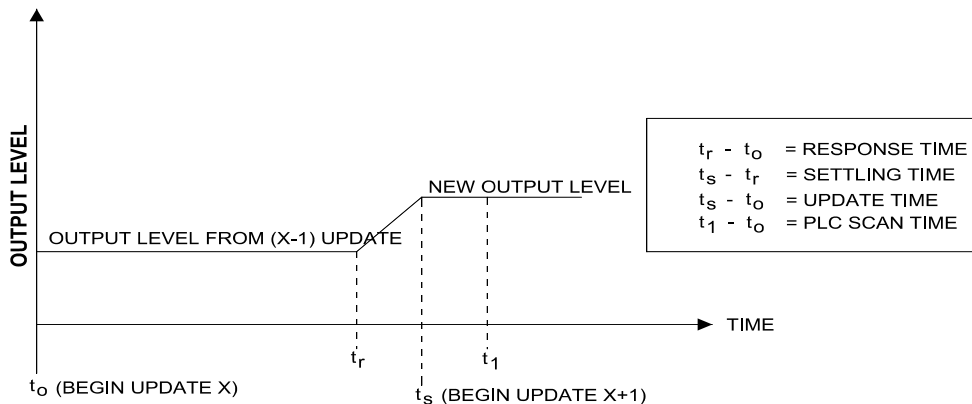

Figure 2 Asynchronous Operation Diagram

## 1.4 Modes of Operation

The 2500C-8-AO supports two modes of operation: *Classic* mode and *Classic Plus* mode. These two modes are selected by jumper JP11 located at the top of the card. Refer to Figure 3 2500C-8-AO JP11 and F3 location on PCB for the location of this jumper. Classic Mode is the default shipping selection.

### 1.4.1 Classic Mode

In *Classic* mode (or Low Density) operation, the 2500C-8-AO logs in to the PLC as an 8 word Output (8WY) module. In *Classic* mode, the module operates in either the 0-20mA range (for current outputs) or  $\pm 5$ VDC (for voltage outputs). To operate the module in  $\pm 5$ VDC voltage you must jumper pins 1 & 4 together on CN6.



## 1.4.2 Classic Plus Mode

In *Classic Plus* mode (or High Density) operation, the 2500C-8-AO logs in to the PLC as an 8 word input / 16 word output (8WX/16WY) module. Error values for each channel are reported to the PLC in the corresponding input word. The WY output words are used to allow the PLC to select the output signal range for the module's channels and write the output value to each channel..

For example, if the module is in *Classic Plus* mode and is logged in at address 1:

WX1 = Channel 1 Status Word	WY9 = Channel 1 DAC data out	WY17 = Channel 1 Configuration
WX2 = Channel 2 Status Word	WY10 = Channel 2 DAC data out	WY18 = Channel 2 Configuration
WX3 = Channel 3 Status Word	WY11 = Channel 3 DAC data out	WY19 = Channel 3 Configuration
WX4 = Channel 4 Status Word	WY12 = Channel 4 DAC data out	WY20 = Channel 4 Configuration
WX5 = Channel 5 Status Word	WY13 = Channel 5 DAC data out	WY21 = Channel 5 Configuration
WX6 = Channel 6 Status Word	WY14 = Channel 6 DAC data out	WY22 = Channel 6 Configuration
WX7 = Channel 7 Status Word	WY15 = Channel 7 DAC data out	WY23 = Channel 7 Configuration
WX8 = Channel 8 Status Word	WY16 = Channel 8 DAC data out	WY24 = Channel 8 Configuration

In *Classic Plus* mode, the PLC can select range operation from any of the following by setting the appropriate bits in the corresponding WY word for each channel. In addition, the PLC can set Offset enable or disable, Unipolar or Bipolar and 5V or 10V range for each channel.

Voltage Ranges	Current Ranges
0-5V	0-20mA
0-10V	$\pm$ 20mA
$\pm$ 5V	4-20mA
$\pm$ 10V	

## 1.5 Output Resolution

Basic resolution of the 2500C-8-AO is 16 bits. Since it can be configured for bipolar operation, the resolution reported to the PLC is 15 bits + sign.

The table below shows the resolution of the module for each scale, and the maximum converted value.

Range	Resolution, per step	Maximum Converted Value
0-5V, $\pm$ 5V	156 $\mu$ V	5.12V
0-10V, $\pm$ 10V	312.5 $\mu$ V	10.24
0-20mA, $\pm$ 20mA	625 $\mu$ A	20 or 24mA depending on configuration see Section 1.8

## 1.6 Accuracy

The module accuracy is 0.15% of full scale (current mode) and 0.15% of full scale (voltage mode)

## 1.7 Digital to Analog Conversion

The digital value representing the desired analog output is written to the module. The module converts the digital value to the analog value for each channel from the corresponding WY word. The digital value is scaled according to

the “0-32000” convention usually used in 2500 Series® PLC applications. A “0” indicates 0V or 0mA. A “32000” indicates full scale volts or mA, with the level depending on the range being used.

The digital value is sent from the PLC in the format shown below:

Sign bit	16,384	8192	4096	2048	1024	512	256	128	64	32	16	8	4	2	1
----------	--------	------	------	------	------	-----	-----	-----	----	----	----	---	---	---	---

In addition to applying a basic scale of 0-32000, the module provides a small overrange capability to convert voltages above the full scale. The maximum valid output value that can be written is +32767 or the lowest value written can be -32767. +32768 will be flagged by Workshop as an INVALID VALUE.

## 1.8 Module Setup from the PLC in Classic Plus Mode

When operating in Classic Plus Mode, the module reads setup information that the PLC has stored in the WY word corresponding to each channel.

WYn	Bit 1	Bit 2	Bit 3	Bit 4	Bits 5-16
Function	0 = Voltage 1 = Current	0 = normal 1 = Offset Enabled	0 = Unipolar 1 = Bipolar	0 = 5V Range 1 = 10V Range	unused

- Bit 1 – sets the channel output to voltage or current ranges
- Bit 2 – sets the channel to a normal or to the Built-in Offset
- Bit 3 – sets the channel ranges to either unipolar or bipolar
- Bit 4 – sets the Voltage Ranges for the channel to either 5V or 10V

Binary & HEX Examples of the Configuration Word for WY17 (Channel 1) X represents a null location		
Binary Example	HEX Example	
0000 xxxx xxxx xxxx	0000	5 Volt Unipolar
0001 xxxx xxxx xxxx	1000	10 Volt Unipolar
0010 xxxx xxxx xxxx	2000	5 Volt Bipolar
0011 xxxx xxxx xxxx	3000	10 Volt Polar
0100 xxxx xxxx xxxx to 0111 xxxx xxxx xxxx	4000	Invalid Configuration, channel output goes to 0 to -1 volt 32752 Error Code is returned in WX1 (Module Status Word for Channel 1)
1000 xxxx xxxx xxxx	8000	20 milliamp Unipolar Current
1001 xxxx xxxx xxxx	9000	24 milliamp Unipolar Current
1010 xxxx xxxx xxxx	A000	20 milliamp Bipolar Current
1011 xxxx xxxx xxxx	B000	24 milliamp Bipolar Current
1100 xxxx xxxx xxxx	C000	4 to 20 milliamp Offset Current
1101 xxxx xxxx xxxx to 1111 xxxx xxxx xxxx	D000 E000 F000	Invalid Configuration, channel output goes to 0 to -1 volt 32752 Error Code is returned in WX1 (Module Status Word for Channel 1)

## 1.9 Error conditions reported:

When in Classic Plus Mode the first 8 WX addresses will report 4 different error codes on a channel by channel basis.

**Underrange** - means the value written to the module is lower than the minimum that can be converted. (example: any negative value for any unipolar range). For this error, a value of “32754” is reported. Note: No underrange error is reported for Bipolar Ranges.

**Invalid Configuration** – means there is configuration error in the WY configuration data given to the module. This error is detected and reported on each channel. For this error, a value of “32752” is reported.

**24V Power Supply Failure** – means the user supplied 24VDC power has gone below 19VDC or above 30VDC. When this occurs the module cannot supply a control signal output on any channel. For this error, a value of “32753” will be reported on all channels.

The table below shows how the module reports for various input signals and range selections.

WX Reported Error Codes			
Range Selection	Output Signal	Value Reported	Comment
All Ranges		00000	No errors reported
0-5V	0v to 5V	00000 to 32000	Valid range
0-10V	0 to 10V	00000 to 32000	Valid range
+5V	+5V	-32000 to 32000	No overrange
+10V	+10V	-32000 to 32000	No overrange
0-20mA	+20.24mA	00000 to 32000	Valid Range
+20mA	-20mA to 20mA	-32000 to 32000	No overrange
These Error Codes are returned in the Channel Status Word regardless of Range or Configuration Selections		32752	Invalid Configuration
		32753	24VDC Power Supply Failure See Section 1.9.1 Application Note for 24VDC User Supplied Power Monitoring

Note: Error Codes are reported when in Classic Plus Mode.

### 1.9.1 Application Note for 24VDC User Supplied Power Monitoring

The 2500C-8-AO constantly monitors the health of the 24VDC user supplied power source, if the power source drops below 19.75 VDC or goes above 31.02 VDC the module reports 32753 back to PLC in all the channel status words or WX addresses. This feature can be very useful in tracking power supply problems by trapping for the error code in the PLC program, recording the time and number of occurrences. When power supplies fail especially on an intermittent basis it can be very difficult to determine exactly what happened, but using this feature can help determine the cause in an easy to implement fashion. This error will also occur if the module fuse F3  is blown, check the fuse if the 24VDC appears good. See Figure 3 2500C-8-AO JP11 and F3 location on PCB . Once power is restored within the acceptable ranges the 2500C-8-AO will automatically clear the error code in the Channel Status Word and return to normal operation.



#### CAUTION – Non-Hazardous Areas/Hazardous Areas

WARNING – EXPLOSION HAZARD. DO NOT REMOVE OR REPLACE WHILE CIRCUIT IS LIVE UNLESS THE AREA IS FREE OF IGNITIBLE CONCENTRATIONS.

AVERTISSEMENT – RISQUE D'EXPLOSION. NE PAS RETIRER NI REMPLACER PENDANT QUE LE CIRCUIT EST SOUS TENSION À MOINS QUE L'EMPLACEMENT NE SOIT EXEMPT DE CONCENTRATIONS INFLAMMABLES.

WARNING – EXPLOSION HAZARD. DO NOT REMOVE OR REPLACE FUSE WHEN ENERGIZED.

AVERTISSEMENT – RISQUE D'EXPLOSION. NE PAS RETIRER NI REMPLACER UN FUSIBLE SI L'APPAREILLAGE EST SOUS TENSION.

Turn off power to the system before replacing fuses either in power supplies or IO modules. Refer to Product Bulletin or Installation and Operation Guide for specific information on the correct fuse for replacement. If there are any questions please contact CTI support. Fuses should only be replaced by qualified technicians.

### 1.10 Using the Module with a Built-In 20% Offset Calculation

You may enable Offset Mode for any channel using bit 3 in the Channel Configuration Word, i.e., 4 to 20 mA or 1 to 5 VDC operation, the 2500C-8-AO will then be configured to automatically scale the digital word from the PLC. Offset Enabled may only be used in Unipolar mode.

4 to 20 mA range       $\text{Digital WY} = ((\text{Output current} - 4) \times 32000) \div 16 \text{ mA}$   
 $\text{WY} = ((\text{Desired Output Current} - 4) \times 32000) \div 16$  for example, to generate an output voltage of 12 mA the WY value output from the PLC is calculated as follows:  $\text{WY} = ((12-4) \times 32000) \div 16 = 16000$

### 1.11 Zero or Last Value Default

The Compact Analog Output Module defaults to Last Value. In Section there is a table showing the modules reaction depending on power fault conditions and communication loss. Please refer to this section 2.8 Output Channel's Reaction to Power Cycling and Communication Loss for a complete description.

---

## **CHAPTER 2 INSTALLATION & SETUP**

---

The installation of the 2500C-8-AO consists of the following steps:

- 1) Reading this Chapter
- 2) Installation planning
- 3) Unpacking and configuring the module,
- 4) Inserting the module into the I/O Base
- 5) Wiring the module output screw terminal connector to the Field Wiring
- 6) Choosing and Connecting the 24VDC user power supply
- 7) Checking module operation.

### **2.1 Installation Planning**

Planning is the first step in the installation of the module. This involves:

1. Calculating the I/O base power budget
2. Selecting a proper user power supply and wiring
3. Routing the wiring to minimize noise
4. Selecting the proper wiring method for the type of output you will use.

The following sections discuss these important considerations of the installation.

#### **2.1.1 Safety Considerations**

Before installing the module, you must identify the personnel hazards that may be created in the event of a system failure and provide interlocks and safety switches and backup control to prevent unsafe operation during a system failure. Refer to the NEMA ICS 3-304 Programmable Control Standards.

#### **WARNING**

**As a system designer, you should be aware that Control devices can fail in an unsafe condition. Unless you incorporate proper safeguards, malfunction of the controller or associated devices, such as operator interface equipment, could cause sudden equipment startup, shutdown, or other unexpected operation. Such startup or shutdown or unexpected operation could result in death or serious injury to personnel, and/or damage to equipment.**

**If you or your company are using CTI controllers with equipment that requires the presence of a person (such as an operator or attendant), you should be aware of this potential safety hazard and take appropriate precautions.**

The precautions below conform to the National Electrical Manufacturers Association guidelines for installation of programmable controllers as recommended in the NEMA ICS 3–304 Programmable Control Standards.

**ICS 3-304.81 Safety Recommendations:**

*Consideration should be given to the use of an emergency stop function which is independent of the programmable controller. Where the operator is exposed to the machinery, such as in loading or unloading a machine tool, or where the machine cycles automatically, consideration should be given to the use of an electromechanical override or other redundant means, independent of the programmable controller, for starting and interrupting the cycle. If provision is required for changing programs while the equipment is in operation, consideration should be given to the use of locks or other means of assuring that such changes can be made only by authorized personnel. These recommendations are intended as safeguards against the failure of critical components and the effects of such failures or the inadvertent errors that might be introduced if programs are changed while the equipment is in operation.*

**Operator Safety Switches**

Power should be configured so that it can be manually removed from all output devices. You must provide a method that is independent of the control system for disconnecting power from the outputs when a machine is not operating or the operator must reach into the machine. A non-electronic switch or directly wired relay must be used to disconnect the power.

**Emergency Stop Switch**

You must provide a method for disconnecting power from the outputs if an emergency situation is encountered with the machine operation. Use a non-electronic switch or relay that is wired external to the controller and that is easily accessible.

**2.1.2 Backplane Power Requirements**

The 2500C-8-AO module consumes 0.75 watts of +5VDC power. To calculate the total power required for the base, you need to add the power requirements for the other modules you will install in the base.

**2.1.3 Choosing a Power Supply for the Analog Outputs**

The 2500C-8-AO requires an external power supply to provide power for the analog outputs. The power supply should be a single voltage, 20-28 VDC nominal 2.0 amp, UL Class 2 device. The compliance of the output circuits is directly related to the output voltage. The drive voltage and current are specified at 24 VDC.

**2.1.4 Electrical Interference**

Electrical interference can adversely affect the operation of control equipment. The major sources of electrical interference in an industrial environment are devices that use high voltages and current, such as motors and welders. Electrical interference can be conducted directly through wiring or inducted via electromagnetic coupling.

To ensure a reliable control system, you will need to determine the source of the electrical interference and employ suitable techniques to eliminate it.

**2.1.5 Grounding**

Lack of proper grounding may cause intermittent or erratic operation or even control system failure. A properly installed grounding system will provide a low-impedance path to earth ground, giving the PLC internal filtering devices a good ground return reference. The building site typically provides a reliable earth ground; however, if excessive ground current is present, a separate grounding electrode should be installed.

A common practice is to provide a central ground bus bar, which is connected to earth ground, as a single point of reference within each enclosure, connect the chassis ground to the bus bar using a 1 inch copper braid or No. 8 AWG copper wire. To ensure good connections, scrape paint or other non-conductive coatings away from mounting studs and from enclosure surfaces where mounting bolts and washers make contact.

In addition to connecting the controller rack and power supply to earth ground, you must ensure that the power supply, controller and all modules installed in the base are installed securely and that the thumbscrews are tightened.

### 2.1.6 Requirements for Signal Wire Carrying Current

You must calculate the loop wiring resistance for any current output circuits. The loop resistance is determined by the length and type of wire, as well as the field device series resistance.

The circuit resistance must not exceed 1000 ohms. If a separate 20 volt power supply is used in the loop, the minimum resistance increases 1000 ohms, and the maximum resistance becomes 2000 ohms. Any value over 1000 ohms prevents the module from operating accurately. The following figure provides a schematic for wiring a loop with a resistance of less than 1000 ohms. It also shows a schematic for adding a power supply to allow loop resistances up to 2000 ohms. Use the following equation to determine the resistance of an output loop for a channel:

$$\text{Resistance} = (2 \times \text{CL} \times \text{RFT}) + \text{TFL}$$

where: CL is the cable length  
RFT is the conductor resistance (ohms/unit length)  
TFL is the resistance of the field device

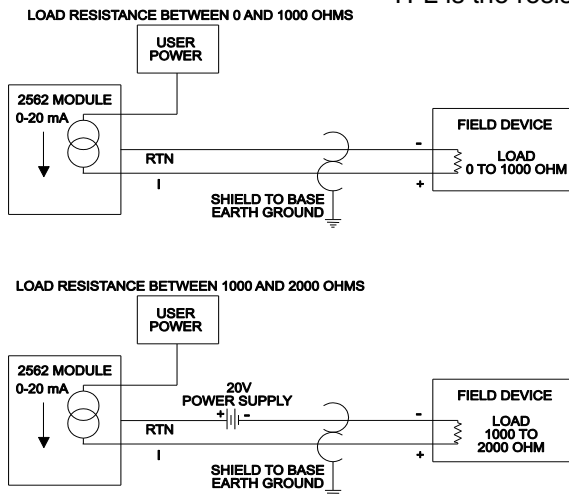

### 2.1.7 Requirements for Signal Wire Providing Voltage

Applications using voltage signals require some special considerations to ensure the module's accuracy. Two additional parameters must be considered:

- Resistive load of the field device
- Capacitance of the cable wiring

The resistive load of the field device must be no lower than 1K ohms. The cable capacitance must be less than 0.01 microfarad.

The cable capacitance is a function of the cable length. To determine the maximum cable length allowed, find the nominal value of cable capacitance per unit length as given by the manufacturer. Use this value in the following equation to determine the maximum cable length:

$$\text{Maximum Cable Length} = \frac{0.01 \text{ microfarads}}{\text{Nominal Cable Capacitance (per unit length)}}$$

**NOTE:**  
*Nominal capacitance is measured between the conductors. However, if one conductor is connected to the shield via a grounded power supply, then the nominal value will usually double in value.*

The length of a cable and the cable conductor resistance are used to find the fixed error which would appear at the field device. Use the following equation to determine the fixed error:

$$\text{Fixed Error (\%)} = \frac{[1-R1] \times 100}{[R1 + 2 \times CL \times RC]}$$

- where: R1 is the field device resistive load
- CL is the cable length
- RC is the conductor resistance per unit length

The following figure provides a schematic for a voltage output circuit.

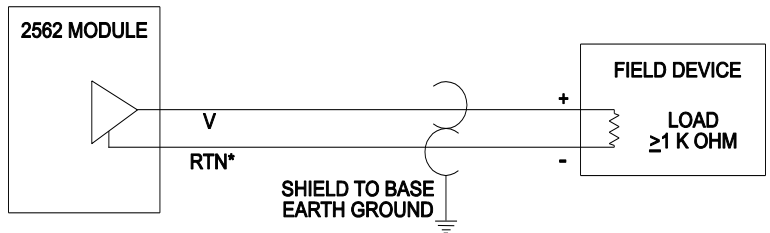



### 2.1.8 Defining Operation Mode and Range Selections

Before you can install the module, you must review your planned input signals by channel and decide on both the operation modes (*Classic* or *Classic Plus*), and the range selections (Voltage or Current) for each output. If your application needs only 0-5V or 0-20mA for every channel, then you may use *Classic* mode. All other ranges require the selection of *Classic Plus* mode.

## 2.2 Unpacking the Module

Open the shipping carton and remove the special anti-static bag that contains the controller. After discharging any static build-up, remove the unit from the static bag. Do not discard the static bag; use it for protection against static damage when the module is not inserted into the I/O base.

### CAUTION

*The components on the 2500C-8-AO printed circuit card can be damaged by static electricity discharge. To prevent this damage, the module is shipped in a special anti-static bag. Static control precautions should be followed when removing the module from the bag and when handling the printed circuit card during configuration.*

## 2.3 Configuring the Module

Prior to inserting the module in the base, you must first configure it for operation based on your requirements identified in Section 2.1.7 above. Configuration includes selecting operation mode and selecting voltage or current for each channel. In addition, if you have selected *Classic Plus* mode, you must configure your PLC program to set the necessary bits in the WY word for the module.

### 2.3.1 Default Factory Configuration

The default setting can only be changed by placing the module in *Classic Plus* Operation Mode and setting the Channel Configuration Word bits (see Section 1.8).

Classic Operation Mode JP11 is in the LD or C position
0 to 20mA Signal Range
Offset Disabled
Unipolar Range

### 2.3.2 Selecting Operation Mode

The operational mode selection is the only jumper to set according to the application requirements. This jumper is JP11 and the selectable positions are Classic labeled as either LD or C or Classic Plus labeled as either HD or CP. The 2500C-8-AO is shipped with the jumper in LD or C.

See Section 1.4 for more information on Classic Mode and Classic Plus Mode.

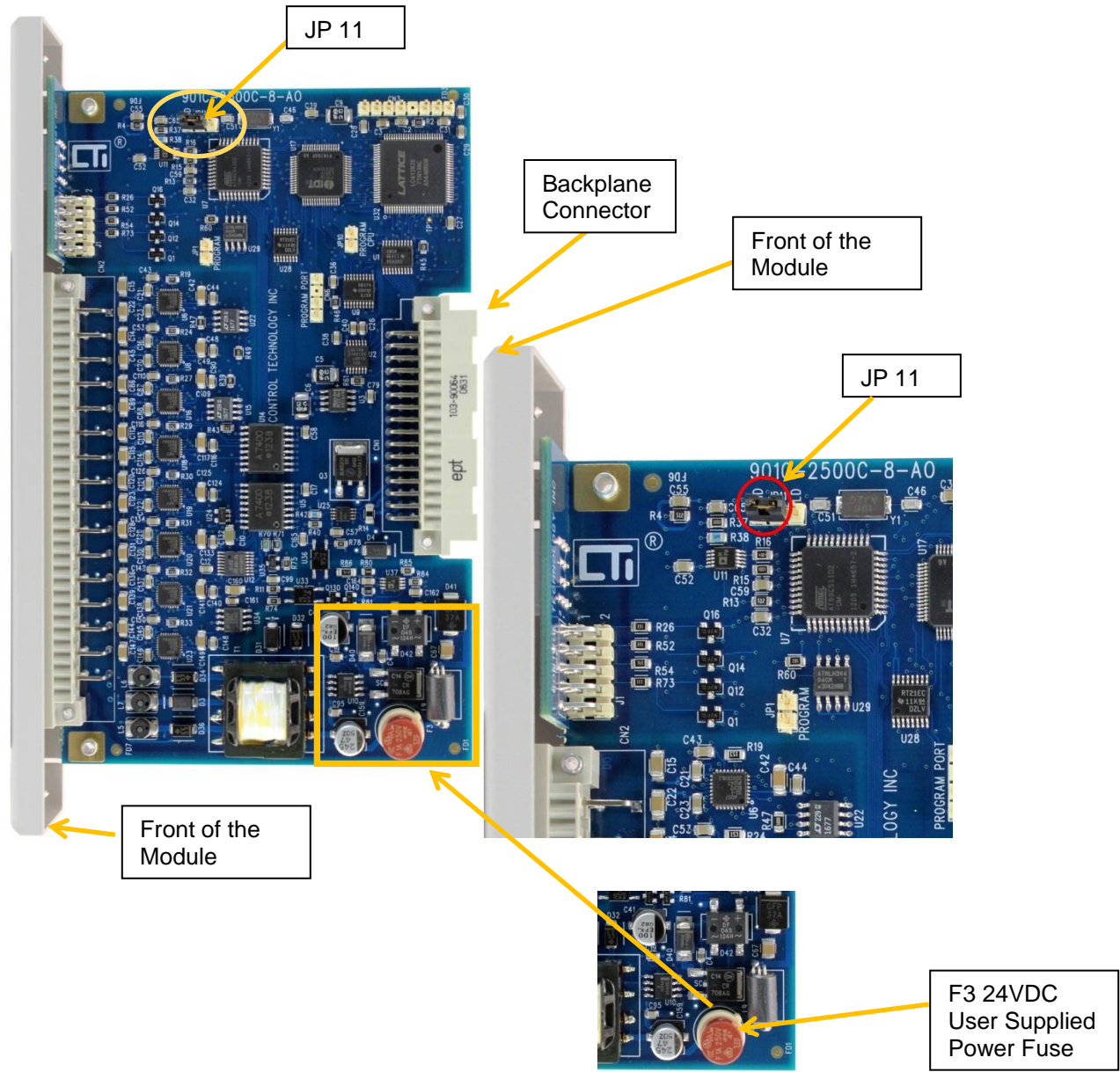
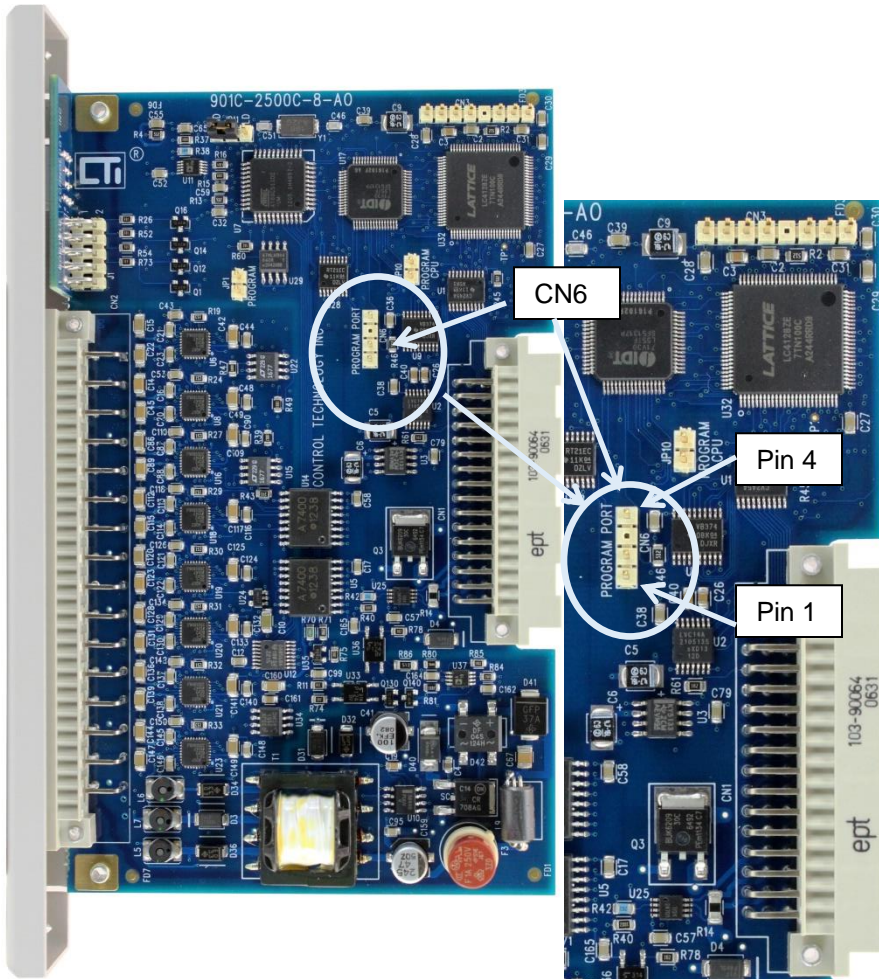

Figure 3 2500C-8-AO JP11 and F3 location on PCB

## 2.4 Selecting $\pm 5\text{VDC}$ Range for Classic Mode Operation



**Figure 4 CN6 Jumper Pins 1 & 4 Location**

The default factory configuration is set to 0-20mA current range. To change the range to  $\pm 5\text{VDC}$  voltage range you must place a jumper on pins 1 and 4 on CN6 shown in Figure 4 CN6 Jumper Pins 1 & 4 Location.

## 2.5 Physical Installation



**Figure 5 Physical Installation Picture**

Remove AC power from the rack. Align the circuit board with the card guide and backplane connector. Slide the controller into the rack until the connector seats. Use the thumbscrews to secure the controller in the rack. Once the module is secured to the rack you may install the wiring connector.

### **⚠ CAUTION REGARDING HOT SWAPPING:**

The 2500C-8-AO is designed to allow “hot-swapping” the module under power in the event that a replacement is needed. However, you must be aware that hot-swapping does not meet UL Safety requirements and is not recommended. If you must “hot-swap” the module, use the following procedure:

1. Make sure all field devices connected to the module are placed into a “safe” state
2. Remove the I/O connector from the front of the module
3. Loosen the module retaining screws and remove it from the base
4. Ensure the jumper configuration of the replacement module matches the one just removed
5. Install the replacement module and tighten the retaining screws. The replacement module must be the same model number as the one removed.
6. Reattach the I/O connector to the module
7. Ensure the replacement module and all other components are operating properly
8. Remove the field devices from “safe” state
9. Return to NORMAL RUN mode

**You are responsible for any results in your application control. DO NOT ATTEMPT TO HOT-SWAP A MODULE IN A HAZARDOUS LOCATION!**

## 2.6 Connecting Field Wiring

Field wiring is connected to the 2500C-8-AI as shown in the connector wiring diagram below. NOTE: For current (0-20mA or 4-20mA) outputs you must wire to the “I+” output terminals. For voltage, wire to the “V+” output terminals. The “Return” or “Common” for each channel is wired to the “Return” terminal and the shield (if any) is wired to the “Earth” terminal.

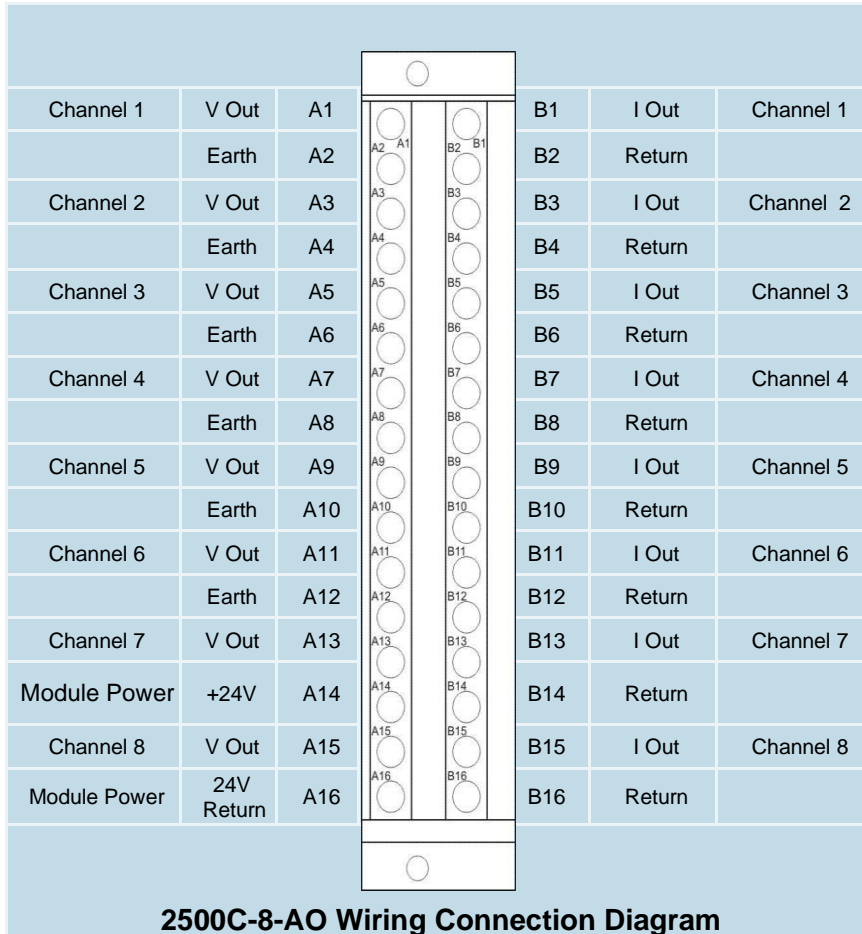

**Figure 6 2500C-8-AO Wiring Connector Diagram**

### NOTE

*The module channels only provide one type of signal range output. For example you cannot use both the voltage and current connection. If your output range is voltage then you would use the V Out connection and the Return connection. If you are using a current range then you would use the I Out and Return connection.*

## 2.7 Initial Power On Indications

Apply power to the base power supply. The Power Good LED on the power supply should illuminate, indicating that power is being supplied to the base connectors. The 2500C-8-AO 7 Segment LED will display 0 indicating the module has passed its internal diagnostics and that no fault conditions exist. The 2500C-8-AO runs its own diagnostics and when this is complete, the status indicators should be in one of the following states:

Indicator	State	Comments
Module Good	0	Once the module completes its internal diagnostics and the 24VDC user supplied power is connected and turned ON, the 7 segment LED will display 0.
Lost or no 24VDC User Supplied Power	P	The 7 segment LED will display P if there is no 24VDC User Supplied Power connected or if the 24VDC Power Source fails during operation. The health of the 24VDC power source is monitored constantly by the 2500C-8-AO.

## 2.8 Output Channel's Reaction to Power Cycling and Communication Loss

The 2500C-8-AO reacts in various ways to different power cycling scenarios and communications loss. These reactions depend on how the module is configured. The different configurations include CLASSIC and Classic PLUS modes. The configuration determines where the configuration comes from and when the module gets its configuration. In Classic Mode the configuration is predetermined so when the module has the 5V backplane it assumes the default range configurations. However, if it is set in Classic Plus mode then the configuration information comes from the logic in the PLC.

Base Power (5V)	User Power (24V)	2500C-8-AO in Classic Mode	
		Unipolar Mode	Bipolar Mode
On	Transition off	Output to zero.	Same
On	Transition on	Output from zero to PLC value.	Same
Transition off	On	Output to zero	Used 10V Bipolar. Output goes to full negative -10V value even if the PLC Value was zero.
Transition on	On	Output from Zero to PLC value.	Used 10V Bipolar. Output goes to full negative -10V to the PLC Value.
Off	Transition on	Output stays at zero.	Same

**Figure 7 Classic Mode Output to Power Cycling in the Local Base**

Base Power (5V)	User Power (24V)	2500C-8-AO in Classic Mode	
		Unipolar Mode	Bipolar Mode
On	Transition off	Output to zero.	In Classic Mode only 5VDC or 20mA unipolar is supported. All other ranges must be configured in Classic Plus Mode. The module ships with 0-20mA signal enabled, 0-5V requires a configuration jumper.
On	Transition on	Output from zero to PLC written value	
Transition off	On	Goes to Zero	
Transition on	On	Output from zero to PLC written value	
Off	Transition on	Output stays at zero.	

**Figure 8 Classic Mode Output to Power Cycling with RIO or Profibus Communications**

Base Power (5V)	User Power (24V)	2500C-8-AO in Classic Mode	
		Unipolar Mode*	Bipolar Mode*
If the RS485 Communications is lost and both the Base Power and 24V User Power are ON the Analog holds the last written value			
On	Transition off	Output to zero.	In Classic Mode only 5VDC or 20mA unipolar is supported. All other ranges must be configured in Classic Plus Mode. The module ships with 0-20mA signal enabled, 0-5V requires a configuration jumper.
On	Transition on	Output to zero .	
Transition off	On	Maintains last value.	
Transition on	On	Goes from zero to last written value.	
Off	Transition on	Output stays at zero.	

**Figure 9 2500C-8-AO Classic Mode Power Cycling without RIO or Profibus Communications**

Base Power (5V)	User Power (24V)	2500C-8-AO in Classic Plus Mode	
		Unipolar Mode*	Bipolar Mode*
On	Transition off	Output to zero.	Output to zero.
On	Transition on	Output zero to PLC written value.	Output from zero to PLC written value
Transition off	On	Output to zero	Fails to – full scale
Transition on	On	Output zero to PLC written value	Goes from – full scale to PLC written value
Off	Transition on	Output stays at zero.	Output stays at zero.

**Figure 10 2500C-8-AO Classic Plus Mode Output Power Cycling with RIO or Profibus Communications**

Base Power (5V)	User Power (24V)	2500C-8-AO in Classic Plus Mode	
		Unipolar Mode*	Bipolar Mode*
If the RS485 Communications is lost and both the Base Power and 24V User Power are ON the Analog holds the last written value.			
On	Transition off	Output to zero.	Output to zero
On	Transition on	Output to zero .	Output to zero
Transition off	On	Output to zero	Fails to – full scale
Transition on	On	Maintains last value.	Goes from – full scale to PLC written value
Off	Transition on	Output stays at zero.	Output to zero

**Figure 11 2500C-8-AO Classic Plus Mode Output Power Cycling without RIO or Profibus Communications**



## CHAPTER 3 *Trouble Shooting*

### 3.1 Status Display

The Status Display is located on the front of the module above the wiring connector. The Status Display will be illuminated with a “0” when the module is functioning normally. If the Status Display is not lit or it’s displaying something other than “0”, then there is an operational problem. Depending on the value displayed or the lack of a lit Display will determine the approach to solving the problem.

Indicator	State	Comments
Module Good	0	Once the module completes it’s internal diagnostics and the 24VDC user supplied power is connected and turned ON, the 7 segment LED will display 0.
RAM Diagnostic Failure	A	Internal CPU RAM Power-up Diagnostic failure. The units must be returned for repair.
Flash Memory Diagnostic Failure	B	Flash Memory Checksum Power-up Diagnostic failure. The units must be returned for repair.
Internal CPU Movx Failure	C	Internal CPU MovX Memory Power-up Diagnostic failure. The units must be returned for repair.
External Dual-port RAM Failure	D	External Shared Dual-port RAM Power-up Diagnostic failure. The units must be returned for repair.
Lost or no 24VDC User Supplied Power	P	The 7 segment LED will display P if there is no 24VDC User Supplied Power connected or if the 24VDC Power Source fails during operation. The health of the 24VDC power source is monitored constantly by the 2500C-8-AO.

### 3.2 WX Error Codes

WX Reported Error Codes		
Range Selection	Value Reported	Problem and Possible Solution
All Ranges	00000	No errors reported
0-5V, 0-10VDC & 0-20mA	00000 to 32000	Valid range
	32754	Under-range. The channel has had a value less than 0 written to it.
±5V, ±10V, & ±20mA	-32000 to 32000	No over-range/under-range reported
		No under-range
These Error Codes are returned in the Channel Status Word regardless of Range or Configuration Selections	32752	Invalid Configuration. The module has been given the wrong configuration from the user logic. Check the values being written to the module channel WX address. See 1.8 Module Setup from the PLC in Classic Plus Mode
	32753	See Section 3.3 24VDC User Supplied Power Source Error

### 3.3 24VDC User Supplied Power Source Error

The 2500C-8-AO constantly monitors the health of the 24VDC user supplied power source, if the power source drops below 19.75 VDC or goes above 31.02 VDC the module reports 32753 back to PLC in all the channel status words or WX addresses. If F3 fuse is blown the same error will be reported. This feature can be very useful in tracking power supply problems by trapping for the error code in the PLC program, recording the time and number of occurrences. When power supplies fail especially on an intermittent basis it can be very difficult to determine exactly what happened, but using this feature can help determine the cause in an easy to implement fashion. Once power is restored within the acceptable ranges the 2500C-8-AO will automatically clear the error code in the Channel Status Word and return to normal operation.

Note: If this Error is reported at all then you have a 24VDC Power Supply Problem even if the power supply checks out good, there is an intermittent problem. If the 24VDC Power Supply checks good then most likely F3 fuse is blown. If the fuse is blown the error will be reported constantly until the fuse is replaced.

**Figure 12 2500C-8-AO Example of Trapping for Power Supply Error Code** is an example ladder rung for trapping for the Power Supply Error Code.

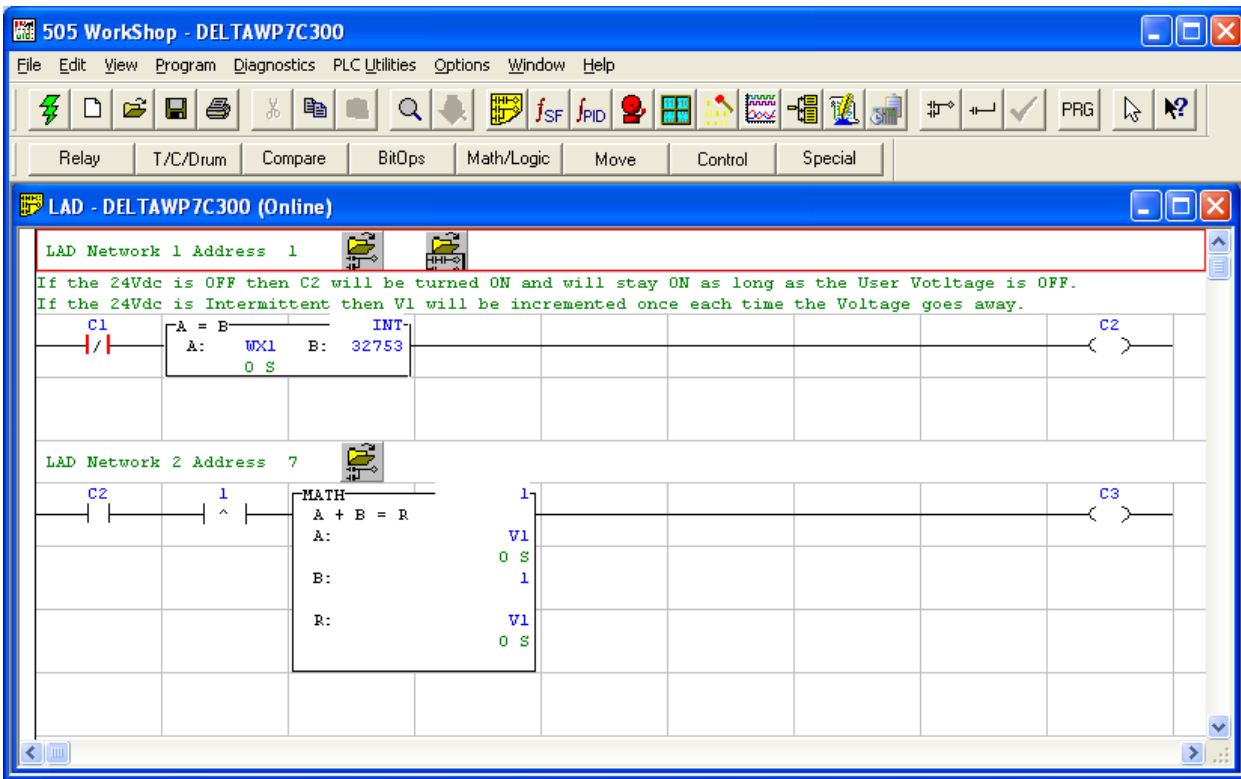

**Figure 12 2500C-8-AO Example of Trapping for Power Supply Error Code**

## Appendix 1 2500C-8-AO Product Specifications

Output Specifications		
Operation Mode Support (See Note 1)	Classic Mode	Classic Plus Mode
8 Analog Output Channels	Supported	Supported
Module Logon	8WY	8WX/16WY
Module Response Time		
Signal Range( Note 2):		
Unipolar Ranges	0 to 5.12 VDC, 0 to 20.24 mA	0 to 10.24 VDC, 0 to 5.12 VDC, 0 to 20.24 mA
Bipolar Ranges	NA	+/- 5.12 VDC +/- 10.24 VDC +/- 20.24 mA

Resolution ( 15 bits plus sign)	
0 to +5.12 VDC or +/- 5.12 VDC	156µV per bit
0 to +10 VDC or +/-10VDC	312.50µV per bit
0 to +20mA or +/-20mA	625µA per bit

	Current Mode	Voltage Mode
Accuracy 0° to 60 °C Voltage Mode	0.15% @25°C	0.15% @ 25°C
Load Resistance (See Note 2)	Min - 0Ω Max - 1kΩ	Min - 1kΩ Max - ∞Ω

User supplied Loop Power	20 to 30VDC @ 0.50 Amps max Maximum Ripple of 0.4V
User supplied 24VDC Power Fusing	1A 250VAC Fast Blow Littelfuse P/N: 37011000410
Backplane Power (MAX)	.312 watts
Input ESD Protection	IEC 1000-4-2 level 4
Isolation	24VDC IN - 500VDC
Connector	2500C-32F
Agency Approvals Pending	UL, ULC, UL Class 1, Div 2, CE
Shipping Dimensions and Weight	223.84mm x 109.86mm x 34.93mm, 0.234kg

Note 1:	Classic or Classic Plus modes are jumper selectable for the module.
Note 2:	In current mode for 600Ωto 1KΩ load user must have a 24V to 30 V Power Supply.



---

## **CTI WARRANTY**

---

Warranty. Control Technology Inc. ("CTI") warrants that this CTI Industrial Product (the "Product") shall be free from defects in material and workmanship for a period of one (1) year from the date of purchase from CTI or from an authorized CTI Industrial Distributor, as the case may be. Repaired or replacement CTI products provided under this warranty are similarly warranted for a period of 6 months from the date of shipment to the customer or the remainder of the original warranty term, whichever is longer. This Product and any repaired or replacement products will be manufactured from new and/or serviceable used parts which are equal to new in the Product. This warranty is limited to the initial purchaser of the Product from CTI or from an authorized CTI Industrial Distributor and may not be transferred or assigned.

2. Remedies. Remedies under this warranty shall be limited, at CTI's option, to the replacement or repair of this Product, or the parts thereof, only after shipment by the customer at the customer's expense to a designated CTI service location along with proof of purchase date and an associated serial number. Repair parts and replacement products furnished under this warranty will be on an exchange basis and all exchanged parts or products become the property of CTI. Should any product or part returned to CTI hereunder be found by CTI to be without defect, CTI will return such product or part to the customer. The foregoing will be the exclusive remedies for any breach of warranty or breach of contract arising therefrom.

3. General. This warranty is only available if (a) the customer provides CTI with written notice of a warranty claim within the warranty period set forth above in Section 1 and (b) CTI's examination of the Product or the parts thereof discloses that any alleged defect has not been caused by a failure to provide a

suitable environment as specified in the CTI Standard Environmental Specification and applicable Product specifications, or damage caused by accident, disaster, acts of God, neglect, abuse, misuse, transportation, alterations, attachments, accessories, supplies, non-CTI parts, non-CTI repairs or activities, or to any damage whose proximate cause was utilities or utility-like services, or faulty installation or maintenance done by someone other than CTI.

4. Product Improvement. CTI reserves the right to make changes to the Product in order to improve reliability, function or design in the pursuit of providing the best possible products.

5. Exclusive Warranty. THE WARRANTIES SET FORTH HEREIN ARE CUSTOMER'S EXCLUSIVE WARRANTIES. CTI HEREBY DISCLAIMS ALL OTHER WARRANTIES, EXPRESS OR IMPLIED. WITHOUT LIMITING THE FOREGOING, CTI SPECIFICALLY DISCLAIMS THE IMPLIED WARRANTIES OF MERCHANTABILITY, FITNESS FOR A PARTICULAR PURPOSE, NON-INFRINGEMENT, COURSE OF DEALING AND USAGE OF TRADE.

6. Disclaimer and Limitation of Liability. TO THE FULLEST EXTENT PERMITTED BY APPLICABLE LAW, CTI WILL NOT BE LIABLE FOR ANY BUSINESS INTERRUPTION OR LOSS OF PROFIT, REVENUE, MATERIALS, ANTICIPATED SAVINGS, DATA, CONTRACT, GOODWILL OR THE LIKE (WHETHER DIRECT OR INDIRECT IN NATURE) OR FOR ANY OTHER FORM OF INCIDENTAL, INDIRECT OR CONSEQUENTIAL DAMAGES OF ANY KIND. CTI'S MAXIMUM CUMULATIVE LIABILITY RELATIVE TO ALL OTHER CLAIMS AND LIABILITIES, INCLUDING OBLIGATIONS UNDER ANY INDEMNITY, WHETHER OR NOT INSURED, WILL NOT EXCEED THE COST OF THE PRODUCT(S) GIVING RISE TO THE CLAIM OR LIABILITY. CTI DISCLAIMS ALL LIABILITY RELATIVE TO GRATUITOUS INFORMATION OR ASSISTANCE PROVIDED BY, BUT NOT REQUIRED OF CTI HEREUNDER. ANY ACTION AGAINST CTI MUST BE BROUGHT

WITHIN EIGHTEEN (18) MONTHS AFTER THE CAUSE OF ACTION ACCRUES. THESE DISCLAIMERS AND LIMITATIONS OF LIABILITY WILL APPLY REGARDLESS OF ANY OTHER CONTRARY PROVISION HEREOF AND REGARDLESS OF THE FORM OF ACTION, WHETHER IN CONTRACT, TORT (INCLUDING NEGLIGENCE AND STRICT LIABILITY) OR OTHERWISE, AND FURTHER WILL EXTEND TO THE BENEFIT OF CTI'S VENDORS, APPOINTED DISTRIBUTORS AND OTHER AUTHORIZED RESELLERS AS THIRD-PARTY BENEFICIARIES. EACH PROVISION HEREOF WHICH PROVIDES FOR A LIMITATION OF LIABILITY, DISCLAIMER OF WARRANTY OR CONDITION OR EXCLUSION OF DAMAGES IS SEVERABLE AND INDEPENDENT OF ANY OTHER PROVISION AND IS TO BE ENFORCED AS SUCH.

7. Adequate Remedy. The customer is limited to the remedies specified herein and shall have no others for a nonconformity in the Product. The customer agrees that these remedies provide the customer with a minimum adequate remedy and are its exclusive remedies, whether based on contract, warranty, tort (including negligence), strict liability, indemnity, or any other legal theory, and whether arising out of warranties, representations, instructions, installations, or non-conformities from any cause. The customer further acknowledges that the purchase price of the Product reflects these warranty terms and remedies.

8. Force Majeure. CTI will not be liable for any loss, damage or delay arising out of its failure (or that of its subcontractors) to perform hereunder due to causes beyond its reasonable control, including without limitation, acts of God, acts or omissions of the customer, acts of civil or military authority, fires, strikes, floods, epidemics, quarantine restrictions, war, riots, acts of terrorism, delays in transportation, or transportation embargoes. In the event of such delay, CTI's performance date(s) will be extended for such length of time as may be reasonably necessary to compensate for the delay.

9. Governing Law. The laws of the State of Tennessee shall govern the validity, interpretation and enforcement of this warranty, without regard to its conflicts of law principles. The application of the United Nations Convention on Contracts for the International Sale of Goods shall be excluded.

---

## ***REPAIR POLICY***

---

In the event that the Product should fail during or after the warranty period, a Return Material Authorization (RMA) number can be requested orally or in writing from CTI main offices. Whether this equipment is in or out of warranty, a Purchase Order number provided to CTI when requesting the RMA number will aid in expediting the repair process. The RMA number that is issued and your Purchase Order number should be referenced on the returning equipment's shipping documentation. Additionally, if the product is under warranty, proof of purchase date and serial number must accompany the returned equipment. The current repair and/or exchange rates can be obtained by contacting CTI's main office at 1-800-537-8398 or go to [www.controltechnology.com/support/repairs/](http://www.controltechnology.com/support/repairs/).

When returning any module to CTI, follow proper static control precautions. Keep the module away from polyethylene products, polystyrene products and all other static producing materials. Packing the module in its original conductive bag is the preferred way to control static problems during shipment. Failure to observe static control precautions may void the warranty.