



# Control Technology Inc.

5734 Middlebrook Pike  
Knoxville, Tennessee 37921  
[www.controltechnology.com](http://www.controltechnology.com)  
Toll Free: 800-537-8398

## 2500 Series <sup>TM</sup> Compact I/O System

**2500C-8-RTD**

**8-CHANNEL RTD INPUT MODULE**

**2500 SERIES® COMPACT I/O**

**INSTALLATION AND OPERATION GUIDE**

Version 1.6

**DO NOT RELEASE UNTIL NEW ANALOG IO UPDATE IS DONE. This  
is a new HARDWARE AND FIRMWARE DESIGN.**

**Copyright© 2024 Control Technology Inc.**

**All rights reserved.**

This manual is published by Control Technology Inc. (CTI) 5734 Middlebrook Pike, Knoxville, TN 37921. This manual contains references to brand and product names which are trade names, trademarks, and/or registered trademarks of Control Technology Inc Series 2500®. Other references to brand and product names are trade names, trademarks, and/or registered trademarks of their respective holders.

### **DOCUMENT DISCLAIMER STATEMENT**

Every effort has been made to ensure the accuracy of this document; however, errors do occasionally occur. CTI provides this document on an “as is” basis and assumes no responsibility for direct or consequential damages resulting from the use of this document. This document is provided without express or implied warranty of any kind, including but not limited to the warranties of merchantability or fitness for a particular purpose. This document and the products it references are subject to change without notice. If you have a comment or discover an error, please call us toll-free at 1-800-537-8398 or email us at [sales@controltechnology.com](mailto:sales@controltechnology.com).

<b>REVISION HISTORY</b>		
<b>Revision</b>	<b>Date</b>	<b>Description</b>
1.0	4/20/2015	Initial Release
1.1	8/17/2017	Corrected Wiring Diagrams in Section 2.6.1
1.2	9/5/2107	Corrected Cross Reference in section 1.2.1
1.3	9/18/2017	Corrected Wiring Diagrams in Section 2.7.1 and other minor corrections or improvements.
1.4	1/16/2024	Added Problem Codes Figure 25. pdb
1.5	2/19/2024	Changed WX9 thru 12 Channel Error Reporting and added WX13 Module Error Reporting.
1.6	7/22/2024	Revised Section 2.6 Physical Installation to add more info on Hot-Swapping

---

## ***PREFACE***

---

This ***Installation and Operation Guide*** provides reference information for the CTI 2500C-8-RTD 8-Channel Thermocouple Module for 2500 Series® Compact I/O system. We assume you are familiar with the operation of CTI 2500 Series® programmable controllers. Refer to the appropriate user documentation for specific information on the 2500 Series® programmable controllers and I/O modules.

This Installation and Operation Guide is organized as follows:

Chapter 1 provides a description of the module.

Chapter 2 covers installation, setup, and wiring.

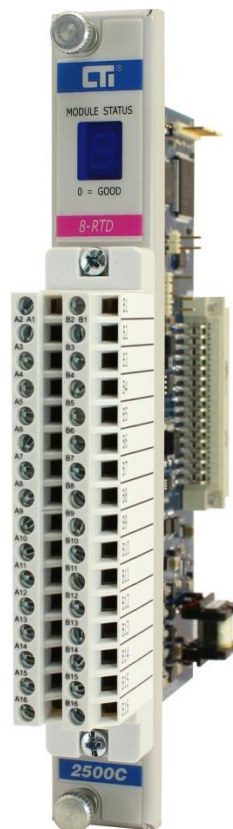

---

## ***USAGE CONVENTIONS***

---

### ***NOTE***

*Notes alert the user to special features or procedures.*

### ***CAUTION***

*Cautions alert the user to procedures that could damage equipment.*

### ***WARNING***

**Warnings alert the user to procedures that could damage equipment and endanger the user.**

---

## **TABLE OF CONTENTS**

---

<b>USAGE CONVENTIONS .....</b>	<b>II</b>
<b>TABLE OF FIGURES .....</b>	<b>5</b>
<b>CHAPTER 1 OVERVIEW .....</b>	<b>6</b>
1.1 Introduction .....	6
1.2 Front Panel Description .....	6
1.2.1 Status Display .....	7
1.2.2 I/O Wiring Connector .....	7
1.3 Asynchronous Operation .....	7
1.4 Modes of Operation .....	7
1.4.1 Classic Mode .....	7
1.4.2 Classic Plus Mode .....	8
1.5 Supported RTD Probes and Input Signal Ranges .....	9
1.5.1 2-Wire, 3-Wire, and 4-Wire RTDs .....	10
1.5.2 Direct Resistive Device Input .....	10
1.6 Measurement Resolution .....	10
1.7 Accuracy .....	10
1.8 Digital Word map .....	10
1.9 RTD Input to Digital Conversion .....	11
1.9.1 Engineering Units .....	11
1.9.2 Scale Units .....	11
1.10 Error Code Values Reported to the PLC .....	11
1.11 Module Setup from the PLC in Classic Plus Mode .....	12
<b>CHAPTER 2 INSTALLATION &amp; SETUP .....</b>	<b>14</b>
2.1 Installation Planning .....	14
2.1.1 Safety Considerations .....	14
2.1.2 Electrical Interference .....	15
2.1.3 Grounding .....	15
2.2 2500C-8-RTD REV-A Board Layout .....	16
2.3 2500C-8-RTD REV-C Board Layout .....	17
2.3.1 Defining Operation Mode and Range Selections .....	18
2.3.2 Power Requirements .....	18
2.4 Unpacking the Module .....	18
2.5 Configuring the Module .....	18
2.5.1 Operation Mode Jumpers - Selecting Operation Mode .....	19
2.5.2 Factory Default Settings .....	19
2.6 Physical Installation .....	20
2.7 Connecting Field Wiring .....	21
2.7.1 Connecting RTD Input Wiring .....	22
2.7.2 Connecting the Shield Wiring .....	23
2.8 Installing the Screw Terminal Connector .....	23
2.9 Calibration of the Module .....	23
<b>CHAPTER 3 CHECKING MODULE OPERATION AND TROUBLESHOOTING .....</b>	<b>24</b>
3.1 Checking Module Operation .....	24
3.2 Troubleshooting .....	25
<b>APPENDIX A MODULE SPECIFICATIONS .....</b>	<b>27</b>

<b>APPENDIX B RTD TEMP VS. RESISTANCE.....</b>	<b>28</b>
<b>CTI WARRANTY.....</b>	<b>29</b>
<b>REPAIR POLICY .....</b>	<b>31</b>

---

## *Table of Figures*

---

Figure 1 2500C-8--RTD Front Panel .....	6
Figure 2 Asynchronous Operation Diagram .....	7
Figure 3 2500C-8-RTD Default Configuration Table .....	7
Figure 4 2500C-8-RTD Classic Plus Login Table .....	8
Figure 5 2500C-8-RTD Classic Plus Profibus Login Dialog Box .....	8
Figure 6 2500C-8-RTD Classic Plus RS485 Remote IO Login Dialog Box .....	9
Figure 7 2500C-8--RTD Measurement Ranges .....	9
Figure 8 2500C-8-RTD RTD Measurement Resolution Table .....	10
Figure 9 2500C-8--RTD Accuracy Rating Table .....	10
Figure 10 2500C-8-RTD Digital Word Map Diagram .....	10
Figure 11 2500C-8-RTD Example of Change in Input Level .....	11
Figure 12 2500C-8-RTD Error Code Table .....	11
Figure 13 2500C-8-RTD Word Map for Channel Configuration Data .....	12
Figure 14 2500C-8-RTD Binary Example of Module Configuration Word .....	13
Figure 15 2500C-8-RTD Board Layout Picture .....	16
Figure 16 2500C-8-RTD Board Layout Picture .....	17
Figure 16 2500C-8-RTD Operation Mode Jumpers Picture .....	19
Figure 17 2500C-8--RTD Default Factory Settings .....	19
Figure 18 2500C-8-RTD Module Physical Installation Picture .....	20
Figure 19 2500C-8-RTD Wiring Connector Diagram .....	21
Figure 20 Typical Circuit – 2 Wire RTD .....	22
Figure 21 Typical Circuit – 3 Wire RTD .....	22
Figure 22 Typical Circuit – 4 Wire RTD .....	22
Figure 23 2500C-8-RTD LED Error Code Table .....	24
Figure 24 2500C-8-RTD Troubleshooting Matrix .....	25
Figure 25 2500C-8-RTD Problem Codes Reported .....	25

---

## CHAPTER 1 OVERVIEW

---

### 1.1 Introduction

The CTI 2500C-8-RTD Eight-Channel RTD Module is a member of Control Technology's family of 2500 Series® Compact I/O modules. It is a single-wide module that is compatible with two-, three-, and four-wire RTDs, with automatic lead wire resistance compensation for three-wire and four-wire RTDs.

The 2500C-8-RTD pulses a small amount of current through the RTD. The module measures the voltage generated by the current through the RTD and determines the resistance. Lookup tables relating temperature to resistance for different RTD probes are used to determine the temperature.

#### Features

- 8 RTD inputs
- Supports Classic and Classic Plus Modes
- 7 Segment Display for Module Status indication
- No user calibration
- Supports 2, 3 and 4 wire RTDs
- Software Configurable Selections
- Uses 2500C-32F removable wiring connector(sold separately)

### 1.2 Front Panel Description

The module front panel provides a 7-segment status display for showing module status, and a 32-pin removable I/O wiring connector.

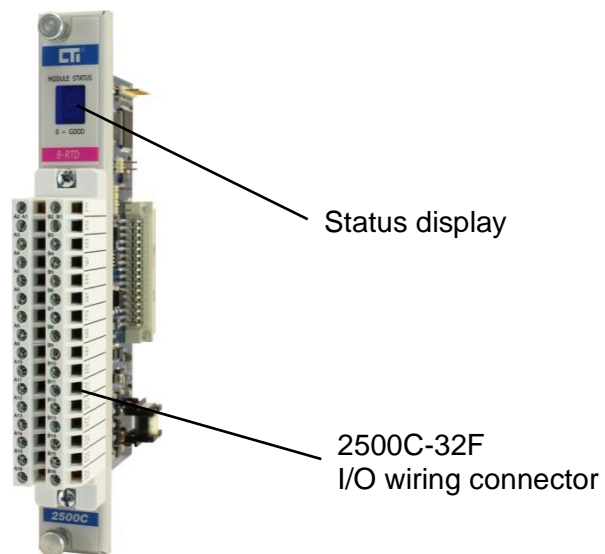

**Figure 1 2500C-8--RTD Front Panel**



### 1.2.1 Status Display

The Status Display will be illuminated with a “0” when the module is functioning normally. If the Status Display is not lit, or if it is displaying something other than “0”, refer to Section 3.1 in Chapter 3 for an explanation of the display codes.

### 1.2.2 I/O Wiring Connector

The 2500C-8-RTD utilizes a standard 32 pin connector, part number 2500C-32F to provide wiring terminals for Channels 1-8 RTD inputs. The wiring connector accepts 14-22 AWG wire.

## 1.3 Asynchronous Operation

The module operates asynchronously with respect to the PLC (a scan of the PLC and input sampling of the module do not occur at the same time). Instead, the module will translate all RTD inputs in one module update (9.0 milliseconds maximum) and store the translated words in buffer memory. The PLC retrieves the stored words from the module buffer memory at the start of the I/O scan.

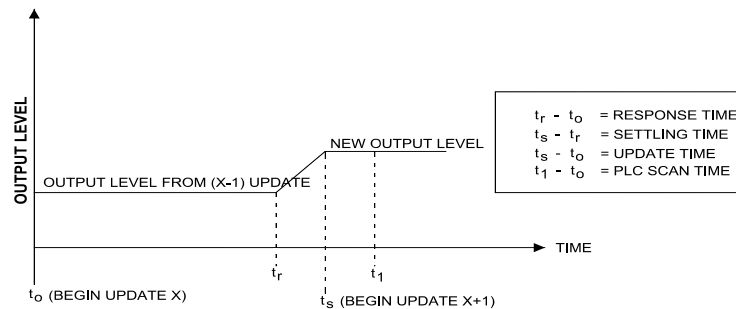

Figure 2 Asynchronous Operation Diagram

## 1.4 Modes of Operation

The 2500C-8-RTD supports two modes of operation: *Classic mode* and *Classic Plus mode*. These two modes are selected by jumper JP11 located at the top of the card. Refer to Figure 15 2500C-8-RTD Board Layout Picture for the location of this jumper. Classic Mode is the default shipping selection.

### 1.4.1 Classic Mode

In *Classic mode* (or Low Density) operation, the 2500C-8-RTD logs in to the PLC as an 8 word Input (8WX) module. Temperature values for each channel are reported to the PLC in the corresponding input word as degrees C. In *Classic mode*, the module accepts 100Ω Pt RTD signal range. To operate the module in other RTD ranges or report the values as degrees F, you must change to *Classic Plus mode*.

#### 1.4.1.1 Classic Mode Module Default Configuration

The 2500C-8-RTD ships in a default configuration which matches a common set of application requirements.

2500-8-RTD Default Shipment Settings	
Operation Mode	Classic Mode
Logon	8WX
RTD	100Ω Pt
RTD Probe Wiring	3 Wire RTD only
Temperature Units	Degrees C

Figure 3 2500C-8-RTD Default Configuration Table

### 1.4.2 Classic Plus Mode

In *Classic Plus* mode (or High Density) operation, the 2500-8-RTD logs in to the PLC as a 16 word input / 8 word output (16WX/8WY) module. Temperature or ohmic signal values or error codes for each channel are reported to the PLC in the corresponding input word. The WY output words are used by the PLC logic to select the input channel configuration for each channel in the module.

For example, if the module is in *Classic Plus* mode and is logged in at address 1:

WX1 = Channel 1 RTD/ $\Omega$ Input	WY17 = Channel 1 Configuration Data
WX2 = Channel 2 RTD/ $\Omega$ Input	WY18 = Channel 2 Configuration Data
WX3 = Channel 3 RTD/ $\Omega$ Input	WY19 = Channel 3 Configuration Data
WX4 = Channel 4 RTD/ $\Omega$ Input	WY20 = Channel 4 Configuration Data
WX5 = Channel 5 RTD/ $\Omega$ Input	WY21 = Channel 5 Configuration Data
WX6 = Channel 6 RTD/ $\Omega$ Input	WY22 = Channel 6 Configuration Data
WX7 = Channel 7 RTD/ $\Omega$ Input	WY23 = Channel 7 Configuration Data
WX8 = Channel 8 RTD/ $\Omega$ Input	WY24 = Channel 8 Configuration Data
WX9 = Channel 1 and 2 Error Code	
WX10 = Channel 3 and 4 Error Code	
WX11 = Channel 5 and 6 Error Code	
WX12 = Channel 7 and 8 Error Code	
WX13 = Channel 5 Module Error Code TBD	
WX14 = Channel 6 Error Code TBD	
WX15 = Channel 7 Error Code TBD	
WX16 = Channel 8 Error Code TBD	

**Figure 4 2500C-8-RTD Classic Plus Login Table**

In Figure 5 2500C-8-RTD Classic Plus Profibus Login Dialog Box the 2500C-8-RTD will be shown as logged in Slot 8 as 16WX and 8WY appear as soon in Slot 8.

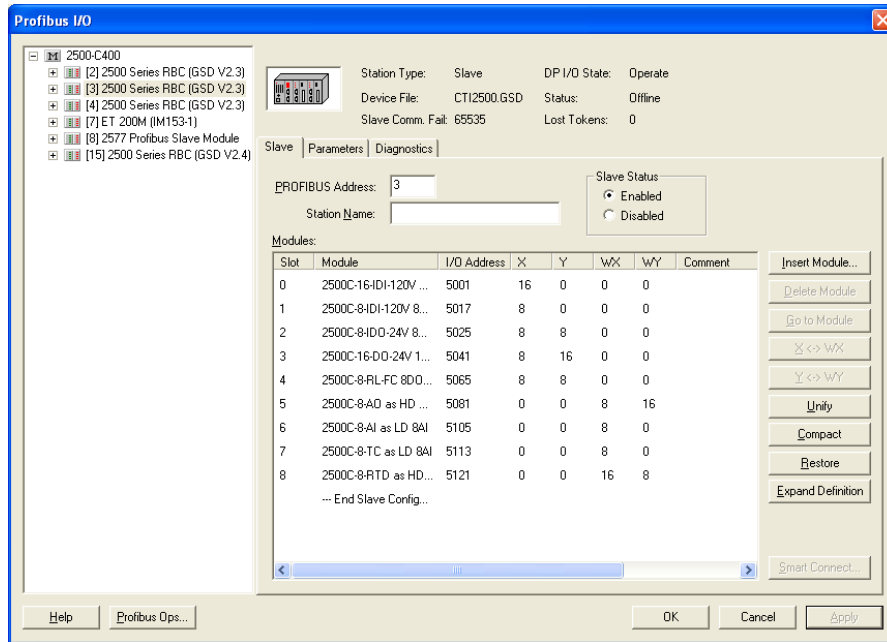

**Figure 5 2500C-8-RTD Classic Plus Profibus Login Dialog Box**

In Figure 6 2500C-8-RTD Classic Plus RS485 Remote IO Login Dialog Box the 2500C-8-RTD is shown as logged in Slot 9 as a 16WX and 8WY.

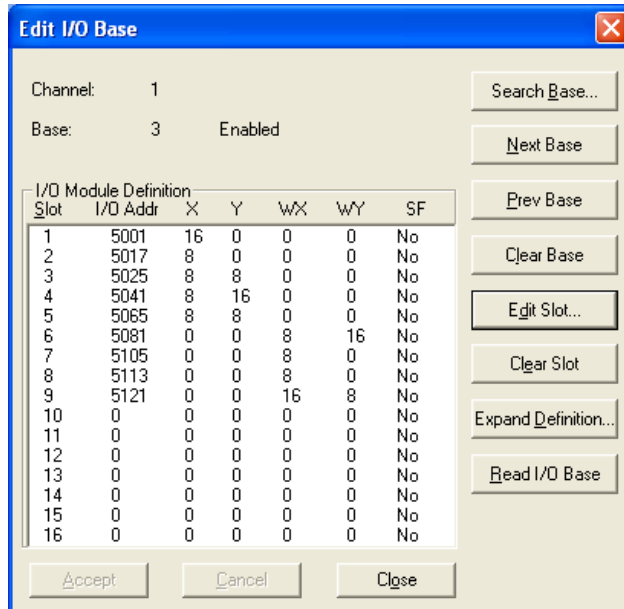

Figure 6 2500C-8-RTD Classic Plus RS485 Remote IO Login Dialog Box

## 1.5 Supported RTD Probes and Input Signal Ranges

In *Classic Plus* mode, the module can be configured by the user logic programmed in the PLC CPU to set the appropriate bits in the corresponding WY word for each channel. This allows the user to configure the RTD ranges, degrees C or F reporting and other operational parameters such as enabling or disabling digital filtering, and enabling or disabling Scaling for each channel.

<b>Supported RTD Probe Types</b>	Platinum 0.003850 (European DIN) Platinum 0.003916 (American) Platinum 0.003902 Platinum 0.003920 Copper 0.004274 Nickel 0.006720 Nickel 0.006178 (European DIN)
<b>Supported Ohm Values @ 0° C</b>	100Ω, 120Ω, 130Ω, 200Ω, 500Ω, 1000Ω, 10Ω, 9.03Ω
<b>Measurement Ranges</b>	10Ω Cu: -100°C to 260°C (-148°F to 500°F) 100Ω Pt: -200°C to 850°C (-328°F to 1562°F) 120Ω Pt: -80°C to 260°C (-112°F to 500°F)
<b>Ohm values reported</b>	10 Ω or 1k Ω

Figure 7 2500C-8--RTD Measurement Ranges

### 1.5.1 2-Wire, 3-Wire, and 4-Wire RTDs

The 2500C-8-RTD supports only 3 wire RTD probes in Classic Mode. In Classic Plus Mode the 2500C-8-RTD supports 2-Wire, 3-Wire, and 4-Wire.

### 1.5.2 Direct Resistive Device Input

Direct ohm inputs to the module are supported for measuring resistive loads or with resistive sensors. Bits in the Configuration Word for each channel are used to select resistance measurement and the order of magnitude of the resistance to be measured (10 Ω or 1k Ω). By selecting 10 Ω Ohm, values are reported as ohms x 100 to the PLC and selecting 1k Ω reports ohms x 10. See Section 1.11 and the example in Figure 14 2500C-8-RTD Binary Example of Module Configuration Word

### 1.6 Measurement Resolution

The module has a resolution of approximately 0.1°C, 0.1°F or exactly .01 millivolts. The chart below shows the corresponding input resolution per step for each of the input configuration modes:

Units	Input Resolution / Step
Temp: C °	0.1°C
Temp: F °	~0.09°F
Ohms	0.0017 millivolts

**Figure 8 2500C-8-RTD RTD Measurement Resolution Table**

### 1.7 Accuracy

The module measurement accuracy is listed below:

Accuracy
100Ω Pt 0.9°C (1.6°F) from 0-60°C Ωx100 0.36Ω from 0-60°C

**Figure 9 2500C-8--RTD Accuracy Rating Table**

### 1.8 Digital Word map

RTD input signals and/or ohmic inputs are translated into a 15-bit plus sign digital word. Since the PLC requires a 16-bit input word, the 15-bit value from the converter is placed into a 16-bit word for transmittal to the PLC, the extra bit being used to show the sign of the value.

The data is reported to the PLC in the format shown below:

Sign bit	16,384	8192	4096	2048	1024	512	256	128	64	32	16	8	4	2	1
----------	--------	------	------	------	------	-----	-----	-----	----	----	----	---	---	---	---

**Figure 10 2500C-8-RTD Digital Word Map Diagram**

In addition to applying a basic scale of 0-32000, the module provides an over-range error value of 32765 or under-range error value of 32766.

## 1.9 RTD Input to Digital Conversion

### 1.9.1 Engineering Units

When module SCALING is disabled, data is reported as engineering units to the PLC as follows:

RTD Mode, digital word (WX) = Degrees x 10  
 OHM Mode, digital word (WX) = -10,000 to +10,000

As an example, the following Figure 11 2500C-8-RTD Example of Change in Input Level illustrates the effects of a change in input level going from 0 to 102.4°F in the Thermocouple Input Mode.

Example 1:

$$0.0^{\circ}\text{F} = (\text{Digital Word (WX)})/10$$

MSB											LSB					
1	2	3	4	5	6	7	8	9	10	11	12	13	14	15	16	
0	0	0	0	0	0	0	0	0	0	0	0	0	0	0	0	
.	.	.	.	.	.	.	.	.	.	.	32	16	8	4	2	1

Example 2:

$$102.4^{\circ}\text{F} = (\text{Digital Word (WX)})/10$$

MSB											LSB					
1	2	3	4	5	6	7	8	9	10	11	12	13	14	15	16	
0	0	0	0	0	1	0	0	0	0	0	0	0	0	0	0	
.	.	.	.	.	1024	.	.	.	.	.	32	16	8	4	2	1

**Figure 11 2500C-8-RTD Example of Change in Input Level**

### 1.9.2 Scale Units

When the data format is selected as Integer, the full temperature range of the RTD is scaled as an unsigned integer from 0 to 32000. The following formulas may be used to calculate the scaled integer value for temperature.

Temperature: Scaled Integer = (measured temp - min temp) / (max temp - min temp) x 32000  
 ex: the scaled integer offset at 0°C for a 100Ω Pt RTD is:  
 Scaled integer = (0 - (-199.8)) / (849 - (-199.8)) x 32000 = 6091

## 1.10 Error Code Values Reported to the PLC

The math overflow code of 32,763 occurs when the RTD and SCALE modes are chosen, and the units tries to report a value under -32,000. The following chart summarizes the 2500C-8-RTD error codes:

Error Code	Error	Comment; Corrective Action
32761	Return Open	
32763	Math Overflow	Low end range of mV/SCALE exceeded; Check process to determine if input is actually low. Determine if mV transmitter is defective.
32764	EEPROM Error	EEPROM Storage Error
32765	Channel Overrange	Input level is above normal input range (see Figure 7 2500C-8--RTD Measurement Ranges for each RTD type); Check process to determine if input is actually high or if the transmitter is defective.
32766	Channel Underrange	Input level is above below input range (see Figure 7 2500C-8--RTD Measurement Ranges for each RTD type); Check process to determine if input is actually low or if the transmitter is defective.

**Figure 12 2500C-8-RTD Error Code Table**

See Section 3.2 Troubleshooting Figure 26 2500C-8-RTD Problem Codes Reported for more.

## 1.11 Module Setup from the PLC in Classic Plus Mode

When operating in Classic Plus Mode, the module gets setup information that the PLC logic has written in the WY word corresponding to each channel. See 1.4.2 for module log on example.

MSB													LSB			
1	2	3	4	5	6	7	8	9	10	11	12	13	14	15	16	
0	0	0	0	0	0	0	0	0	0	0	0	0	0	0	0	
Not Used				Not Used				Not Used								

**Figure 13 2500C-8-RTD Word Map for Channel Configuration Data**

Bit 1 – Unused

Bit 2 through 4 – Sets RTD Type

- 111 - Platinum 0.003850 DIN
- 110 - Platinum 0.003916
- 101 - Platinum 0.003902
- 100 - Platinum 0.003920
- 011 - Copper 0.004274
- 010 - Nickel 0.006720
- 001 - Nickel 0.006178 DIN
- 000 - No RTD Type selected defaults to Ohm

Bit 5 – Unused

Bit 6 through Bit 8 are used to set the input channel ohmic value

- 111 - 100 ohm x 10
- 110 - 120 ohm x 10
- 101 - 130 ohm x 10
- 100 - 200 ohm x 10
- 011 - 500 ohm x 10
- 010 - 1K ohm x 10
- 001 - 10 ohm x 100
- 000 - 9.03 ohm x 100

Bit 9 – Three wire/ Four wire RTD

- 0 - Three Wire RTD
- 1 - Four Wire RTD/ Two Wire RTD

Bit 10 – Digital Filtering

- 0 - Disabled
- 1 - Enabled

Bit 11 and 12 are used to set the Digital Filtering Time Constant

- 00 - 1000 mS
- 01 - 4000 mS
- 10 - 8000 mS
- 11 - 16000mS

Bit 13 and 14 are Unused

Bit 15 and 16 are used to set the input value reported units

- 11 - Degrees F x 10
- 10 - Degrees C x 10
- 01 - Ohms
- 00 - Integer

Binary Examples of the Configuration Word for WY9 (Channel 1) X represents a null location	
x100 x111 1100 xx11	Module is set for Platinum, 100 $\Omega$ , 4 wire, Digital Filtering, w/time constant 1000mS, °F
X000 x111 0101 xx01	Module is set for ohm, 100 ohm x 10, 3 wire, Digital Filtering, w/time constant 4000 mS, Ohms units reported
100x x010 xxxx xxxx	Module is set for °F, Digital Filtering, Scaling Enable, Type J

**Figure 14 2500C-8-RTD Binary Example of Module Configuration Word**

---

## **CHAPTER 2    INSTALLATION & SETUP**

---

The installation of the 2500C-8-RTD consists of the following steps:

- 1) Reading this Chapter
- 2) Installation planning
- 3) Unpacking the module
- 4) Configuring the module
- 5) Physical installation
- 6) Connecting field wiring
- 7) Checking operation

### **2.1 Installation Planning**

#### **2.1.1 Safety Considerations**

Before installing the module, you must identify the personnel hazards that may be created in the event of a system failure and provide interlocks and safety switches to prevent operation during a system failure. Refer to the NEMA ICS 3-304 Programmable Control Standards.

#### **WARNING**

**As a system designer, you should be aware that Control devices can fail in an unsafe condition. Unless you incorporate proper safeguards, malfunction of the controller or associated devices, such as operator interface equipment, could cause sudden equipment startup, shutdown, or other unexpected operation. Such startup or shutdown or unexpected operation could result in death or serious injury to personnel, and/or damage to equipment.**

**If you or your company are using CTI controllers with equipment that requires the presence of a person (such as an operator or attendant), you should be aware of this potential safety hazard and take appropriate precautions.**

The precautions below conform to the National Electrical Manufacturers Association guidelines for installation of programmable controllers as recommended in the NEMA ICS 3–304 Programmable Control Standards.

#### **ICS 3-304.81 Safety Recommendations:**

*Consideration should be given to the use of an emergency stop function which is independent of the programmable controller. Where the operator is exposed to the machinery, such as in loading or unloading a machine tool, or where the machine cycles automatically, consideration should be given to the use of an electromechanical override or other redundant means, independent of the programmable controller, for starting and interrupting the cycle. If provision is required for changing programs while the equipment is in operation, consideration should be given to the use of locks or other means of assuring that such changes can be made only by authorized personnel. These recommendations are intended as safeguards against the failure of critical components and the effects of such failures or the inadvertent errors that might be introduced if programs are changed while the equipment is in operation.*

#### **Operator Safety Switches**

Power should be configured so that it can be manually removed from all output devices. You must provide a method that is independent of the control system for disconnecting power from the outputs when a machine is not operating or the operator must reach into the machine. A non-electronic switch or directly wired relay must be used to disconnect the power.



### **Emergency Stop Switch**

You must provide a method for disconnecting power from the outputs if an emergency situation is encountered with the machine operation. Use a non-electronic switch or relay that is wired external to the controller and that is easily accessible.

### **2.1.2 Electrical Interference**

Electrical interference can adversely affect the operation of control equipment. The major sources of electrical interference in an industrial environment are devices that use high voltages and current, such as motors and welders. Electrical interference can be conducted directly through wiring or inducted via electromagnetic coupling.

To ensure a reliable control system, you will need to determine the source of the electrical interference and employ suitable techniques to eliminate it.

### **2.1.3 Grounding**

It is very important that all equipment is properly grounded. Lack of proper grounding may cause intermittent or erratic operation or may cause the control system to fail. A properly installed grounding system will provide a low-impedance path to earth ground, which will give all PLC internal filtering devices a good ground return for reference. The earth ground of the building site typically provides reliable grounding; however, if excessive ground current is present, a separate grounding electrode should be installed.

A common practice is to provide a central ground bus bar as a single point of reference within each enclosure, connecting all chassis and power supply components to the bus bar. The bus bar is then connected to earth ground. When connecting to the bus bar, use 1 inch copper braid or No. 8 AWG wire. To ensure good connections, scrape paint or other non-conductive coatings away from mounting studs and from enclosure surfaces where mounting bolts and washers make contact.

In addition to connecting the controller rack and power supply to earth ground, you must ensure that the power supply, controller and all modules installed in the base are installed securely and that the thumbscrews are tightened.

## 2.2 2500C-8-RTD REV-A Board Layout

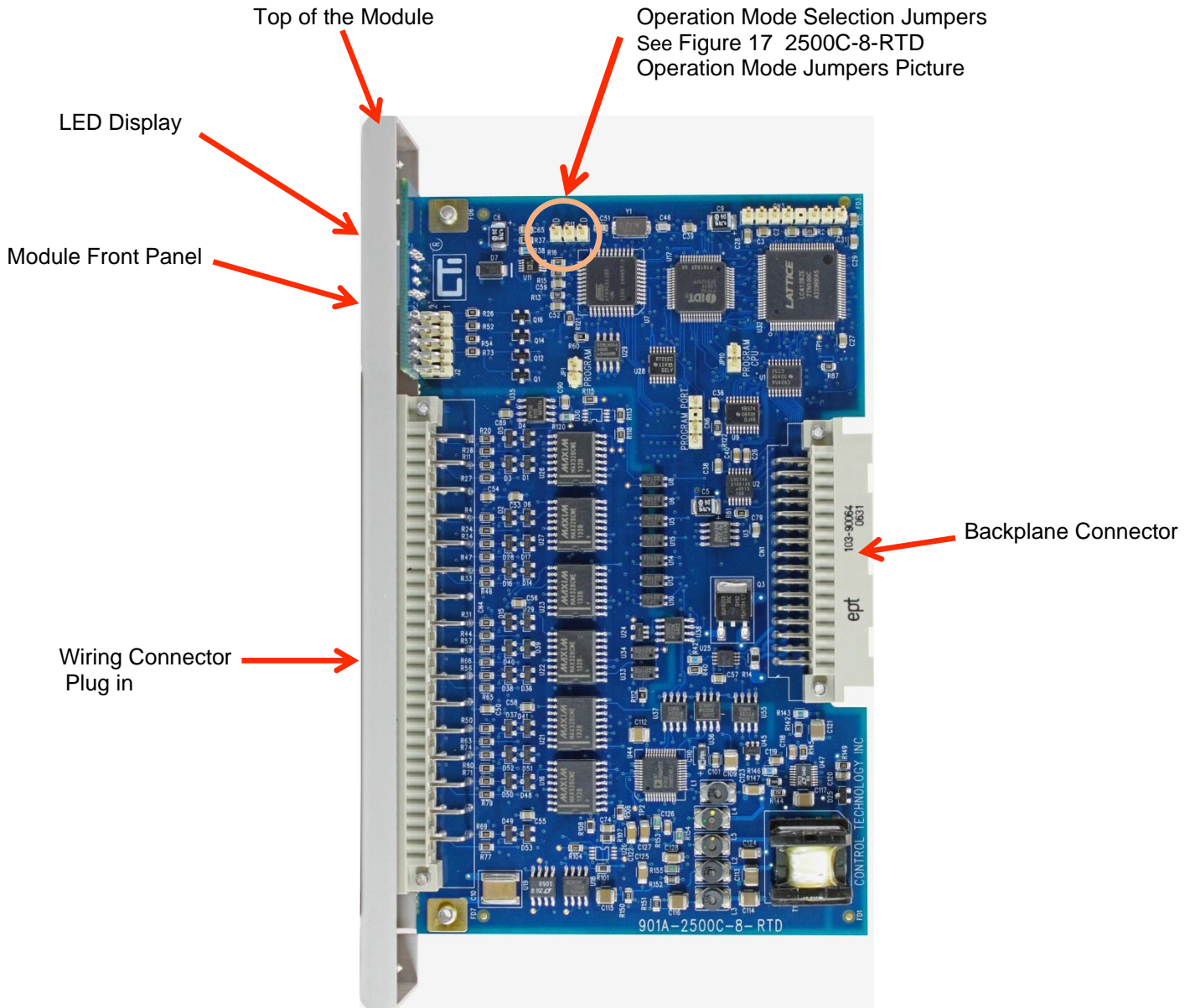

**Figure 15 2500C-8-RTD Board Layout Picture**

### 2.3 2500C-8-RTD REV-C Board Layout

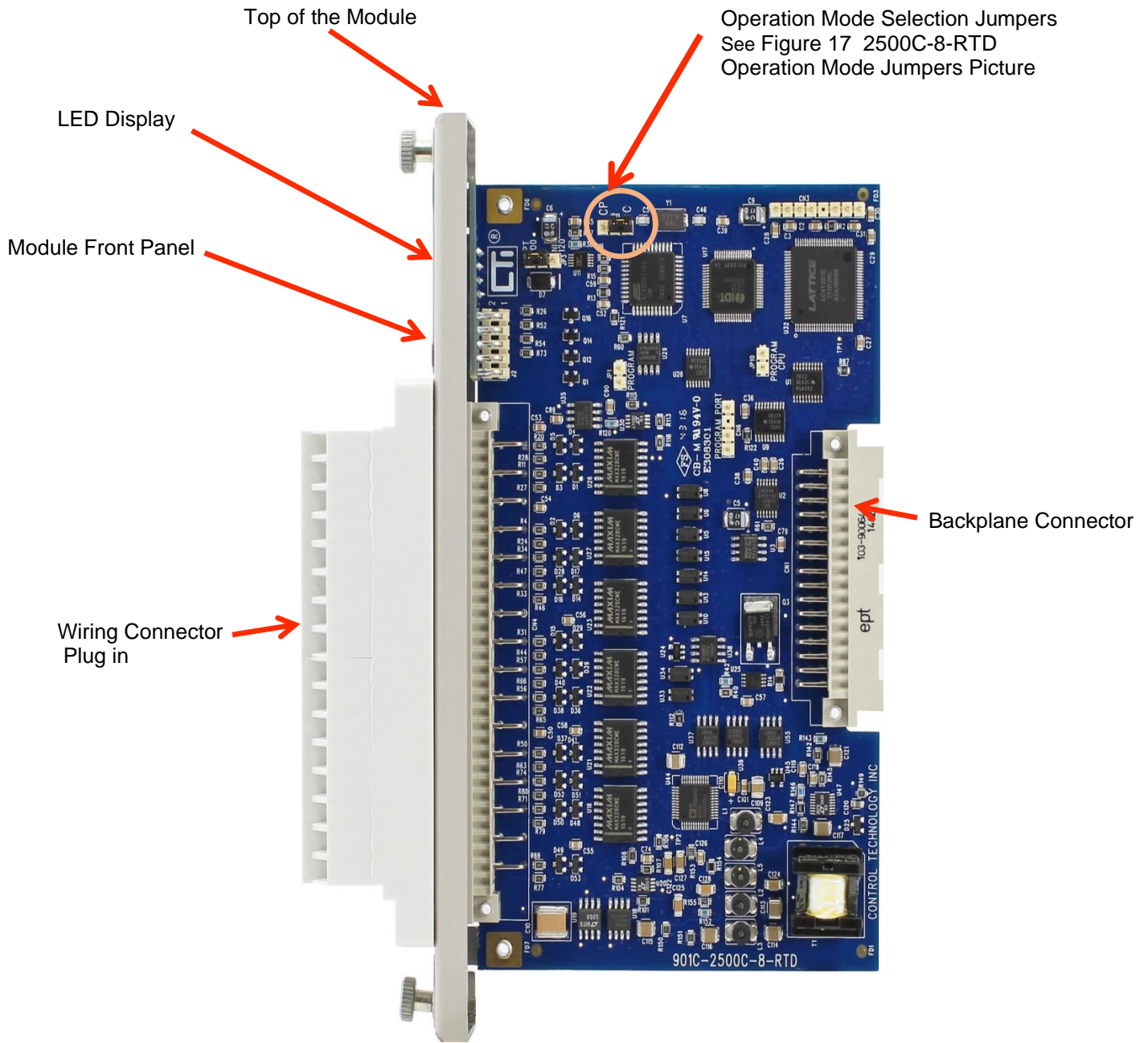

Figure 16 2500C-8-RTD Board Layout Picture

### 2.3.1 Defining Operation Mode and Range Selections

Before you can install and use the module, you must review your planned input signals by channel and decide on one of the operation modes (*Classic* or *Classic Plus*), and the range selections and settings for each input. If your application needs only 100Ω Pt 3 wire RTD with digital filtering enabled and degree measurements in Centigrade for every channel, then you may use *Classic* mode. All other ranges and options require the selection of *Classic Plus* mode and will be configured in your PLC logic.

### 2.3.2 Power Requirements

The 2500C-8-RTD module consumes 1.123 watts of +5VDC power. To calculate the total power required for the base, you need to add the power requirements for the other modules you will install in the base.

## 2.4 Unpacking the Module

Open the shipping carton and remove the special anti-static bag that contains the controller. After discharging any static build-up, remove the unit from the static bag. Do not discard the static bag; use it for protection against static damage when the module is not inserted into the I/O base.

#### CAUTION

*The components on the 2500C-8-RTD printed circuit card can be damaged by static electricity discharge. To prevent this damage, the module is shipped in a special anti-static bag. Static control precautions should be followed when removing the module from the bag and when handling the printed circuit card during configuration.*

## 2.5 Configuring the Module

Prior to inserting the module in the base, you must first configure it for operation based on your requirements identified in Section 2.3.1 above. Configuration includes selecting operation mode and selecting signal type, digital filtering, scaling and degrees F or C reporting for each channel. In addition, if you have selected *Classic Plus* mode, you must configure your PLC program to set the necessary bits in the WY word for the module.

#### NOTE

*Remember the module configuration must be reflected not only in the jumper selections but also in the Channel Configuration Words that is written to the module from the CPU. This requires logic in the application program to make this happen.*

*See section 1.11 Module Setup from the PLC in Classic Plus Mode*

### 2.5.1 Operation Mode Jumpers - Selecting Operation Mode

The module operational mode is selecting using the jumper at JP11. For *Classic* mode, the jumper should be installed at the “LD” position. For *Classic Plus* mode it should be installed at the “HD” position. The module ships from the factory set for *Classic* mode operation or in the “LD” position.

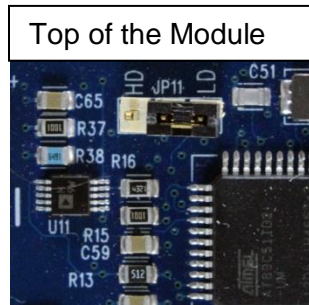

**Figure 17 2500C-8-RTD Operation Mode Jumpers Picture**

#### NOTE

*JP1 is used for factory test purposes and should not be populated. If your module has a jumper at JP1 PROGRAM position please remove before inserting the module.*

### 2.5.2 Factory Default Settings

The 2500C-8-RTD default configuration as shipped from the factory is listed in the table below:

2500-8-RTD Default Shipment Settings	
Operation Mode	Classic Mode
Logon	8WX
RTD	100Ω PT
Digital Filtering	Enabled Time constant= 1000mS
Temperature Units	Degrees C

**Figure 18 2500C-8--RTD Default Factory Settings**

## 2.6 Physical Installation

Remove AC power from the rack. Align the circuit board with the card guide and backplane connector. Slide the module into the rack until the connector seats. Use the thumbscrews to secure the module in the rack. Once the module is secured to the rack you may install the wiring connector.



**Figure 19 2500C-8-RTD Module Physical Installation Picture**

### **⚠ CAUTION REGARDING HOT SWAPPING:**

The 2500C-8-RTD is designed to allow “hot-swapping” the module under power in the event that a replacement is needed. However, you must be aware that hot-swapping does not meet UL Safety requirements and is not recommended. If you must “hot-swap” the module, use the following procedure:

1. Make sure all field devices connected to the module are placed into a “safe” state
2. Remove the I/O connector from the front of the module
3. Loosen the module retaining screws and remove it from the base
4. Ensure the jumper configuration of the replacement module matches the one just removed
5. Install the replacement module and tighten the retaining screws. The replacement module must be the same model number as the one removed.
6. Reattach the I/O connector to the module
7. Ensure the replacement module and all other components are operating properly
8. Remove the field devices from “safe” state
9. Return to NORMAL RUN mode

**You are responsible for any results in your application control. DO NOT ATTEMPT TO HOT-SWAP A MODULE IN A HAZARDOUS LOCATION!**

## 2.7 Connecting Field Wiring

Field wiring is connected to the 2500C-8-RTD as shown in the connector wiring diagram below. NOTE: For ohm inputs you may wire to the “Source and Sense +” and the “Source and Sense -” connections.

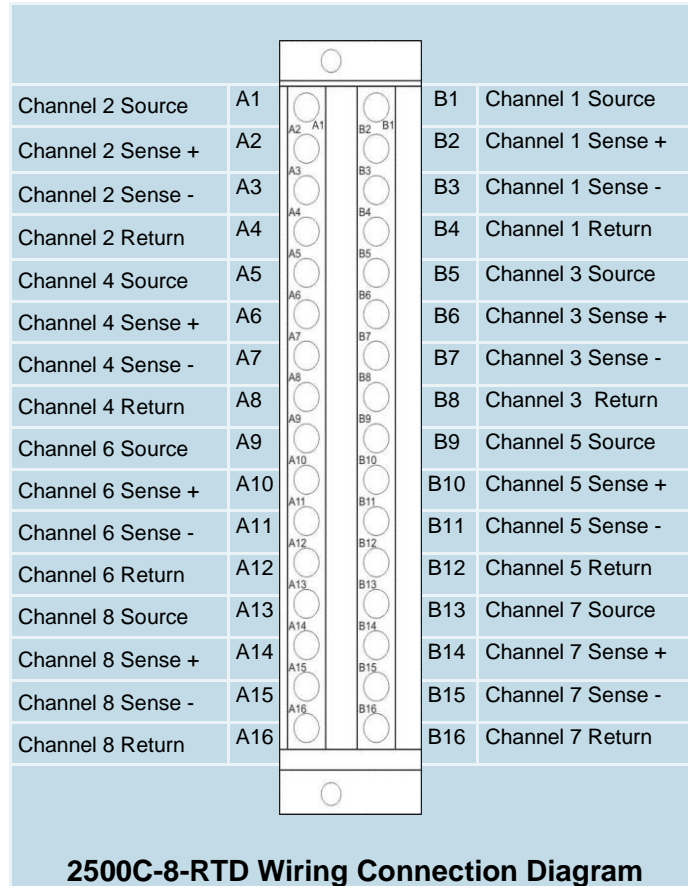

**Figure 20 2500C-8-RTD Wiring Connector Diagram**

### 2.7.1 Connecting RTD Input Wiring

For RTD input circuits, connect the RTD wires to the screw terminals, as indicated in Figure 20 2500C-8-RTD Wiring Connector Diagram. Insert the wires in the appropriate wiring connections on the front of the connector. When the wires are inserted, tighten the screws. Repeat this procedure for the all RTD input channels. Ensure that the proper wire polarity is followed for each of the supported RTD probe types, as shown in Figure 21 Typical Circuit – 2 Wire RTD, Figure 22 Typical Circuit – 3 Wire RTD and Figure 23 Typical Circuit – 4 Wire RTD.

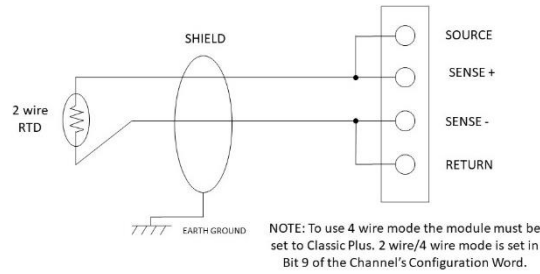

**Figure 21 Typical Circuit – 2 Wire RTD**

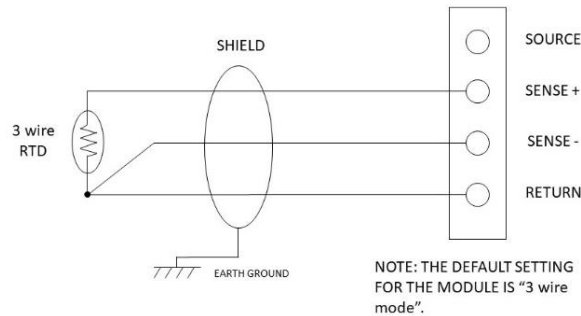

**Figure 22 Typical Circuit – 3 Wire RTD**

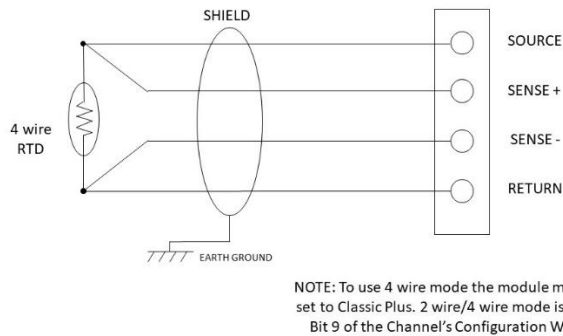

**Figure 23 Typical Circuit – 4 Wire RTD**



### **2.7.2 Connecting the Shield Wiring**

Control Technology Inc. recommends that all wires be shielded twisted pair with a foil wrap shield and a separate drain wire and that they be installed in a metallic conduit. For millivolt applications, use Belden cable 8761 or equivalent which contains a foil wrap shield and a separate drain wire. The shield and the foil wrap should be twisted together and should be terminated at only one end. The other end should be left in an open circuit condition. CTI recommends that the shield be terminated at the PLC end of the signal wire. Special components are installed on the module to aid in the rejection of noise.

When entering the industrial cabinet the shield should be routed from the main terminal strip all the way to the PLC. Signal leads that do not maintain a shield from the terminal strip to the PLC act as antennas and are susceptible to radiated and conducted emissions in the cabinet. Unprotected cables may introduce measurement errors in the module.

CTI strongly recommends that the shielded wires be terminated to the PLC chassis ground.

CTI has exhaustively tested this product to maximize its ability to reject noise from inductive sources as well as showering arcs, fast transients and other high frequency generators and has determined that the best performance results from connecting all shield wires together at the PLC module and terminating this single wire to the chassis ground with a large current capacity conductor. CTI recommends using a #8 gauge wire or larger from the PLC chassis to the earth ground connection.

## **2.8 Installing the Screw Terminal Connector**

When all the input signal wires are connected to the screw terminal connector, carefully install the connector on the front of the module.

## **2.9 Calibration of the Module**

The 2500C-8-RTD RTD Input Module is calibrated at the factory. No further calibration is required. All calibration parameters are stored in non-volatile memory. There are no user adjustments on this product.

---

## **CHAPTER 3    Checking Module Operation and Troubleshooting**

---

### **3.1    Checking Module Operation**

Apply power to the base power supply. The Front Panel LED on the power supply will display “0” if there are no problems found and the module is properly working. The Remote Base Controller will take a few seconds to complete the startup sequence. When this is complete, the status indicator on the 2500C-8-RTD should display a “0”. Any other value displayed indicates the module has detected a problem or error. If the 7 segment Status LED displays any other value than “0” the module will need to be returned to CTI for repair.

<b>Status Indicator</b>	<b>Comments</b>
0	Normal operation
A	Defective Internal RAM – contact CTI for assistance
b	Code Memory Failure – contact CTI for assistance
C	Internal MOVx RAM Failure – contact CTI for assistance
d	Shared RAM failure – contact CTI for assistance
L	Lookup Tables for RTD to Temperature Flash Failure

**Figure 24 2500C-8-RTD LED Error Code Table**

**NOTES:**

*1. In the event the 2500C-8-RTD detects an onboard module failure, the module will assert the module fail line and report the module failure in the I/O Status Word, which is reported to the PLC CPU. CTI strongly recommends the user application monitor the I/O Module Status Words which are Status Words 11-26. The I/O Module Status Word can be used to report a module failure for an I/O Module in any of the 2500C I/O slots. If a module failure is reported by the status word, the module should be replaced with a working unit and the failed module sent in for repair.*

*2. It may take 15 – 30 minutes after initial installation for temperature readings to stabilize.*

**CAUTION:**

*For proper operation, ensure that the 2500C-8-RTD and the RTD wires are not subjected to drafts or large temperature gradients during operation.*

## 3.2 Troubleshooting

<u>Symptom</u>	<u>Probable Cause</u>	<u>Corrective Action</u>
Status LED is not lit.	Base or PLC power is off.	Turn base or PLC on.
Status LED displays something other than "0"	Module has failed.	Return to CTI for repair.
Incorrect inputs.	Wrong addresses for word input. Not logged in.	Check program for correct word input addresses Read I/O configuration.
Input does not work with PID loop or analog alarm block.	Value is not reported as integer 0-32,000.	Select INTEGER format in the Channel Configuration Word.
Value is too large.	Temperature is reported to PLC as value x10.	Divide value by 10 in PLC.
Incorrect values to PLC. (values off by 10-15 degrees)	Incorrect Channel Configuration  Wrong RTD type selected  Unbalanced lead wires  Signal wire noise	Verify selections in the Channel Configuration Word  Check lead resistance.  Refer to Section 2.1.2

**Figure 25 2500C-8-RTD Troubleshooting Matrix**

If after consulting Figure 25 2500C-8-RTD Troubleshooting Matrix, you are unable to diagnose the problem, contact CTI at 1-800-537-8398 for further assistance.

<b>Signed Integer</b>	<b>Hex Code</b>	<b>Problem</b>	<b>Description</b>	<b>Corrective Action</b>
32767	7FFF	Not used		
32766	7FFE	Input under range	RTD input is below expected range	Check configuration. Check wiring, sensor.
32765	7FFD	Input overrange	RTD input is above expected range	Check configuration. Check wiring, sensor.
32764	7FFC	Not Used		
32763	7FFB	Sense short	Short from Sense to Return (3-wire)	Check wiring, sensor.
32762	7FFA	Input not wired/ No front panel connector	All inputs are open or improperly wired	Wire module channel.
32761	7FF9	Return open	Return to Sense - $\geq 18.5K \Omega$	Check Return wire.
32760	7FF8	Not used		
32759	7FF7	Source Open	Used only in 4 wire mode	Check wiring, sensor
32758	7FF6	Sensor Open	Sensor or Sense + Open	Check wiring, sensor.
32757	7FF5	Not used		
32756	7FF4	Not used		
32755	7FF3	Not used		
32754	7FF2	Not used		
32753	7FF1	Invalid RTD Type selected	Invalid selection of RTD material, TCR, and $\Omega$ combination	Select Valid RTD Type
32752	7FF0	Not used		
3	0003	Three/Two-wire mode	Module is correctly performing 3/2-wire conversions for this input (separate error words only)	Module channel functioning properly

**Figure 26 2500C-8-RTD Problem Codes Reported**



## Appendix A Module Specifications

Input Specifications		
Operation Mode Support (See Note 1)	Classic Mode	Classic Plus Mode
Channels	8 RTD Inputs	
Module Logon	8WX	8WX/8WY
Module Update Time all modes	9 mSec	
Digital Filtering Time Constant	1000 mSec or 1 second	
Supported RTD Types	Platinum 0.003850 (European DIN) Platinum 0.003916 (American) Platinum 0.003902 Platinum 0.003920 Copper 0.004274 Nickel 0.006720 Nickel 0.006178 (European DIN)	
Supported Ohm Values @ 0° C	100Ω, 120Ω, 130Ω, 200Ω, 500Ω, 1000Ω, 10Ω, 9.03Ω	
Measurement Ranges	10Ω Cu: -100°C to 260°C (-148°F to 500°F) 100Ω Pt: -200°C to 850°C (-328°F to 1562°F) 120Ω Pt: -80°C to 260°C (-112°F to 500°F)	
Supported Probe Types	2, 3, 4 Wire	
RTD Excitation Current	250μA	
Lead Compensation	1000Ω per lead wire (max)	
Repeatability	±0.1°C, ±0.2°C for all RTD Types	
Measurement Units	Degrees C or Degrees F selectable	
Resolution ( 15 bits plus sign)	0.1°C	
Accuracy	100Ω Pt 0.9°C (1.6°F) from 0-60°C Ωx100 0.36Ω from 0-60°C	
Common Mode Rejection	>130db @ 60Hz	
Normal Mode Rejection	-80db @ 60Hz,	
Backplane Power (MAX)	1.123 watts	
Input ESD Protection	IEC 1000-4-2 Level 4	
Over-range Protection	30VDC or VAC continuous	
Isolation	Channel to Backplane 1500VDC	
Operating Temperature Range	0°C to 60°C (32°F to 140°F)	
Agency Approvals Pending	UL, ULC, UL Class 1, Div 2, CE	
Shipping Dimensions and Weight	223.84mm x 109.86mm x 34.93mm, 0.234kg	
Storage Temperature Range	-40°C to 85°C (-40°F to 185°F)	
Relative Humidity	5% to 95% (non-condensing)	

## **Appendix B RTD Temp vs. Resistance**

**Table C-1 Platinum 0.003850 DIN**

°F	°C	100 Ω	200 Ω	500 Ω
-328	-200	18.49	36.99	92.47
-148	-100	60.25	120.51	301.27
32	0	100.00	200.00	500.00
212	100	138.50	277.00	692.50
392	200	175.84	351.68	879.20
572	300	212.02	424.04	1060.09
752	400	247.04	494.08	1235.19
932	500	280.90	561.79	1404.48
1112	600	313.59	627.19	1567.97
1292	700	345.13	690.26	1725.66
1472	800	375.51	751.02	1877.55
1562	850	390.26	780.53	1951.31

**Table C-2 120-ohm Nickel**

°F	°C	0.00672	DIN
			0.006178
-112	-80	66.60	72.59
-58	-50	86.16	89.11
32	0	120.00	120.00
122	50	157.75	154.93
212	100	200.64	194.14
302	150	248.95	238.39
392	200	303.45	288.95
482	250	366.53	347.57
527	275	401.69	380.60

**Table C-3 10-ohm Copper 0.004274**

°F	°C	Ohms
-328	-200	1.17
-238	-150	3.44
-148	-100	5.68
-58	-50	7.86
32	0	10.00
122	50	12.14
212	100	14.27
302	150	16.41
392	200	18.57
482	250	20.73

---

## **CTI WARRANTY**

---

Control Technology Inc. ("CTI") warrants that this CTI Industrial Product (the "Product") shall be free from defects in material and workmanship for a period of one (1) year from the date of purchase from CTI or from an authorized CTI Industrial Distributor, as the case may be. Repaired or replacement CTI products provided under this warranty are similarly warranted for a period of 6 months from the date of shipment to the customer or the remainder of the original warranty term, whichever is longer. This Product and any repaired or replacement products will be manufactured from new and/or serviceable used parts which are equal to new in the Product. This warranty is limited to the initial purchaser of the Product from CTI or from an authorized CTI Industrial Distributor and may not be transferred or assigned.

2. Remedies. Remedies under this warranty shall be limited, at CTI's option, to the replacement or repair of this Product, or the parts thereof, only after shipment by the customer at the customer's expense to a designated CTI service location along with proof of purchase date and an associated serial number. Repair parts and replacement products furnished under this warranty will be on an exchange basis and all exchanged parts or products become the property of CTI. Should any product or part returned to CTI hereunder be found by CTI to be without defect, CTI will return such product or part to the customer. The foregoing will be the exclusive remedies for any breach of warranty or breach of contract arising therefrom.

3. General. This warranty is only available if (a) the customer provides CTI with written notice of a warranty claim within the warranty period set forth above in Section 1 and (b) CTI's examination of the Product or the parts thereof discloses that any alleged defect has not been caused by a failure to provide a suitable environment as specified in the CTI Standard Environmental Specification and applicable Product specifications, or damage caused by accident, disaster, acts of God, neglect, abuse, misuse, transportation, alterations, attachments, accessories, supplies, non-CTI parts, non-CTI repairs or activities, or to any damage whose proximate cause was utilities or utility-like services, or faulty installation or maintenance done by someone other than CTI.

4. Product Improvement. CTI reserves the right to make changes to the Product in order to improve reliability, function or design in the pursuit of providing the best possible products.

5. Exclusive Warranty. THE WARRANTIES SET FORTH HEREIN ARE CUSTOMER'S EXCLUSIVE WARRANTIES. CTI HEREBY DISCLAIMS ALL OTHER WARRANTIES, EXPRESS OR IMPLIED. WITHOUT LIMITING THE FOREGOING, CTI SPECIFICALLY DISCLAIMS THE IMPLIED WARRANTIES OF MERCHANTABILITY, FITNESS FOR A PARTICULAR PURPOSE, NON-INFRINGEMENT, COURSE OF DEALING AND USAGE OF TRADE.

6. Disclaimer and Limitation of Liability. TO THE FULLEST EXTENT PERMITTED BY APPLICABLE LAW, CTI WILL NOT BE LIABLE FOR ANY BUSINESS INTERRUPTION OR LOSS OF PROFIT, REVENUE, MATERIALS, ANTICIPATED SAVINGS, DATA, CONTRACT, GOODWILL OR THE LIKE (WHETHER DIRECT OR INDIRECT IN NATURE) OR FOR ANY OTHER FORM OF INCIDENTAL, INDIRECT OR CONSEQUENTIAL DAMAGES OF ANY KIND. CTI'S MAXIMUM CUMULATIVE LIABILITY RELATIVE TO ALL OTHER CLAIMS AND LIABILITIES, INCLUDING OBLIGATIONS UNDER ANY INDEMNITY, WHETHER OR NOT INSURED, WILL NOT EXCEED THE COST OF THE PRODUCT(S) GIVING RISE TO THE CLAIM OR LIABILITY. CTI DISCLAIMS ALL LIABILITY RELATIVE TO GRATUITOUS INFORMATION OR ASSISTANCE PROVIDED BY, BUT NOT REQUIRED OF CTI HEREUNDER. ANY ACTION AGAINST CTI MUST BE BROUGHT WITHIN EIGHTEEN (18) MONTHS AFTER THE CAUSE OF ACTION ACCRUES. THESE DISCLAIMERS AND LIMITATIONS OF LIABILITY WILL APPLY REGARDLESS OF ANY OTHER CONTRARY PROVISION HEREOF AND REGARDLESS OF THE FORM OF ACTION, WHETHER IN CONTRACT, TORT (INCLUDING NEGLIGENCE AND STRICT LIABILITY) OR OTHERWISE, AND FURTHER WILL EXTEND TO THE BENEFIT OF CTI'S VENDORS, APPOINTED DISTRIBUTORS AND OTHER AUTHORIZED RESELLERS AS THIRD-PARTY BENEFICIARIES. EACH PROVISION HEREOF WHICH PROVIDES FOR A LIMITATION OF LIABILITY, DISCLAIMER OF WARRANTY OR CONDITION OR EXCLUSION OF DAMAGES IS SEVERABLE AND INDEPENDENT OF ANY OTHER PROVISION AND IS TO BE ENFORCED AS SUCH.

7. Adequate Remedy. The customer is limited to the remedies specified herein and shall have no others for a nonconformity in the Product. The customer agrees that these remedies provide the customer with a minimum adequate remedy and are its exclusive remedies, whether based on contract, warranty, tort (including negligence), strict liability, indemnity, or any other legal theory, and whether arising out of warranties, representations, instructions, installations, or non-conformities from any cause. The customer further acknowledges that the purchase price of the Product reflects these warranty terms and remedies.

8. Force Majeure. CTI will not be liable for any loss, damage or delay arising out of its failure (or that of its subcontractors) to perform hereunder due to causes beyond its reasonable control, including without limitation, acts of God, acts or omissions of the customer, acts of civil or military authority, fires, strikes, floods, epidemics, quarantine restrictions, war, riots, acts of terrorism, delays in transportation, or transportation embargoes. In the event of such delay, CTI's performance date(s) will be extended for such length of time as may be reasonably necessary to compensate for the delay.

9. Governing Law. The laws of the State of Tennessee shall govern the validity, interpretation and enforcement of this warranty, without regard to its conflicts of law principles. The application of the United Nations Convention on Contracts for the International Sale of Goods shall be excluded.



---

## ***REPAIR POLICY***

---

In the event that the Product should fail during or after the warranty period, a Return Material Authorization (RMA) number can be requested orally or in writing from CTI main offices. Whether this equipment is in or out of warranty, a Purchase Order number provided to CTI when requesting the RMA number will aid in expediting the repair process. The RMA number that is issued and your Purchase Order number should be referenced on the returning equipment's shipping documentation. Additionally, if the product is under warranty, proof of purchase date and serial number must accompany the returned equipment. The current repair and/or exchange rates can be obtained by contacting CTI's main office at 1-800-537-8398 or go to [www.controltechnology.com/support/repairs/](http://www.controltechnology.com/support/repairs/).

When returning any module to CTI, follow proper static control precautions. Keep the module away from polyethylene products, polystyrene products and all other static producing materials. Packing the module in its original conductive bag is the preferred way to control static problems during shipment. Failure to observe static control precautions may void the warranty.